

### POWER RATING

Production tolerance : ± 3%

MODEL	CONDITIONS	POWER	rpm	Base Engine
MD196T	HEAVY DUTY	280PS (206kW)	2,000	DE12T

**Note : 1)** No reduction in rating for intake air temperature is up to 45 °C (318K) and sea water temperature is up to 32 °C (305K) , relative humidity is up to 60 % all data are based on operation to ISO 3046.

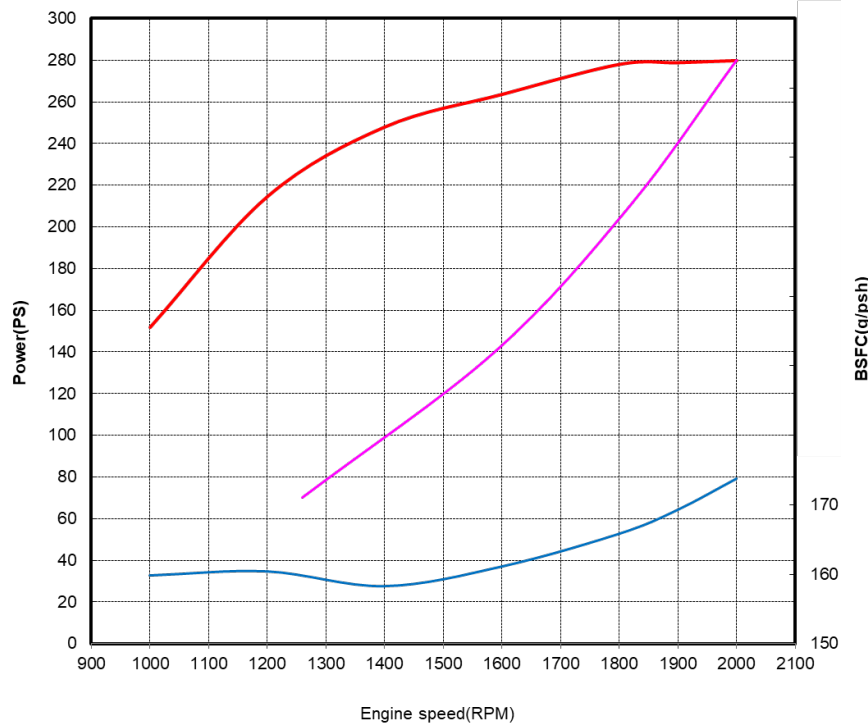
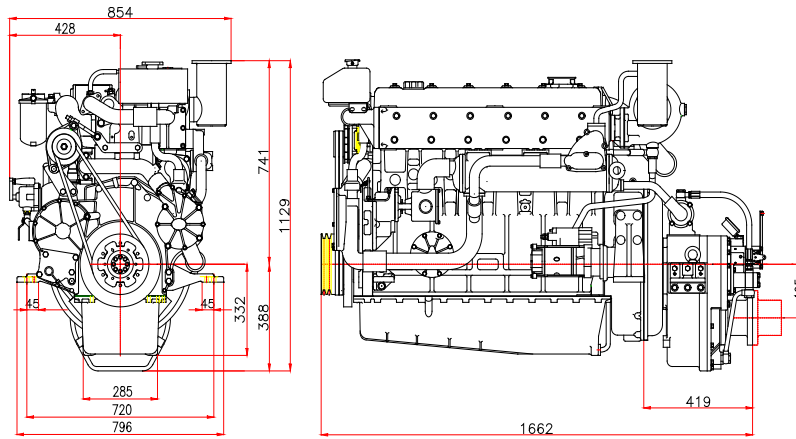

- **Heavy Duty :** Operation hours are unlimited per year, at average load is up to 90 % ,  
At full load is up to 80 %  
Typical gearbox ratio: 2.5 ~ 6  
(Fishing trawler, Tug boat, Pushing vessel, Cargo boat, Freighter, Ferry)

Engine Specification			
Model		Units	MD196T
Engine type			4 cycle, In line, direct- injection, water cooled with wet turbo charger
Rating output (B.H.P)		PS(kW)/rpm	280(206)/2,000
Displacement		cc	11,051
Cylinder number - bore(φ) x stroke		mm	6 - φ123 x 155
Valve clearance at cold	In / Ex	mm	0.3 / 0.3
Low idling rpm		rpm	725 ± 25
No load max. rpm		rpm	below 2,200
Mean effective pressure		kg/cm <sup>2</sup>	11.41
Mean piston speed		m/sec.	10.33
Compression ratio			17.1 : 1
Firing order			1 - 5 - 3 - 6 - 2 - 4
Max. firing pressure of cylinder		kg/cm <sup>2</sup>	106
Compression pressure	at 200 rpm	kg/cm <sup>2</sup>	28 (Initial condition)
Governor type of injection pump			Mechanical variable speed (R.Q.V)
Fuel consumption		g/PS.h	169
		lit / h	57
Injection timing (B.T.D.C)		deg	14 <sup>0</sup> ±1 <sup>0</sup>
Fuel inj. nozzle opening pressure		kg/cm <sup>2</sup>	220
Starting system			Electric Starting by starter motor
Starter motor capacity		V- kW	24 - 5.4
Alternator capacity		V- A	24 - 80
Battery		V- Ah	24 - 150
Cooling system			Indirect sea water cooling with heat exchanger
Cooling water capacity	Max. / Min.	lit	24 / 19
Fresh water pump type			Centrifugal type, driven by gear
Sea water pump type			Rubber impeller type driven by gear
Lubricating oil (Engine)	Pan capacity	lit	Max : 25, Min : 19 ( Engine total : 27)
	Pressure	kg/cm <sup>2</sup>	Full : 3.5, Idle : 1.2
Marine gear	Model		DMT136H ( Dong-1)
	Gear ratio		1.97 2.57 3.08 3.46
Direction of revolution	Crankshaft		Counter clockwise viewed from stern side
	Propeller		Clockwise viewed from stern side
Engine size (L x W x H)	Without M/G	mm	1,243 x 854 x 1,073
	With M. gear	mm	1,662 x 854 x 1,129
Engine dry weight	Without M/G	kg	975
	with M. gear	kg	1,225

psi = kg/cm<sup>2</sup> x 14.22  
lb/ft. = N.m x 0.737  
kW = 0.2388 kcal/s

lb= kg x 2.205  
lb/PS.h = g/kW.h x 0.00162  
cfm = m<sup>3</sup>/min x 35.3

hp = PS x 0.98635  
U.S gal. = liter x 0.264



### Head office

HD Hyundai Group's Global R&D Center 477,  
Bundangsuseo-ro, Seongnam-si Gyeonggi-do,  
Korea (13553)

### Sales office (Engine)

11F, HD Hyundai Group's Global R&D Center

※ Specifications are subject to change without prior notice.