

HYUNDAI

4AD158C



MARINE

Power Rating

Conditions	Model	Max. Power		rpm	Emission
		kW	PS		
50Hz	4AD158CA(F)	386	525	1500	IMO Tier II/III EPA Tier 3
60Hz	4AD158CA(S)	463	630	1800	

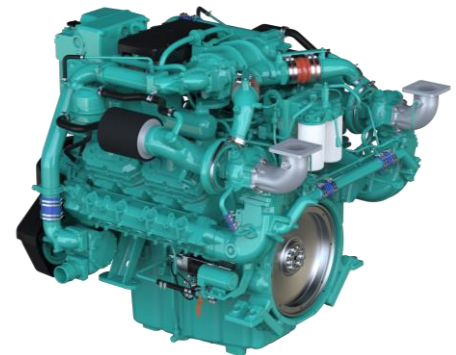

* No reduction in rating for intake air temperature is up to 45°C (318K) and sea water temperature is up to 32°C (305K), relative humidity is up to 60%

* All data are based on operation to ISO 3046. Performance tolerance of ±3%

Key Features and Benefit

High Performance

- Advanced fuel injection system with common rail
- Compliance with emission regulation (IMO Tier II/III, EPA Tier 3)
- High-efficiency SCR
- Smoke reduction
- Increased durability of key components

Convenience

- Auto tensioner
- Turning device
- Electrical oil drain pump
- CCV for engine room cleanliness

Economical

- Decreasing fuel consumption to average 5% by downsizing
- Increased oil & filter replacement cycle (250hr → 500hr)

Warranty

- Maximum 3 years warranty provided through extended warranty option

Engine Specifications

Engine Model	4AD158C (DX15)
Cylinders and Arrangement	8-cylinder / V type
Bore x Stroke	128 x 147 mm
Displacement	15.1 liter
Compression Ratio	17.6 : 1
Firing Order	1-5-7-2-6-3-4-8
Direction of Revolution	Counterclockwise viewed from Flywheel
Fuel system	Common rail controlled by ECU
Starting system	Electric starting by starter motor
Starter motor capacity	24V - 7.0A
Alternator capacity	24V - 80Ah
Battery	24V - 200Ah
Aspiration	Wet turbocharger & intercooler
Flywheel Housing	SAE #1 (FW: 14")
Cooling system	Heat exchanger / Keel Cooling
Cooling water capacity	Max: 77 liter, Min : 72 liter
Fresh water pump type	Centrifugal (Pulley type)
Sea water pump type	Rubber Impeller
After Treatment System	IMO Tier-II / EPA Tier 3 : Not Required IMO Tier-III : SCR
Lubricant Oil	Oil pan capacity Max : 50 liter, Min : 25 liter Pressure Full load : 3.5, Idle : 1.2 (kg /cm ²)
Dimension (L x W x H)	1564 x 1310 x 1380 mm
Dry Weight	1555 kg

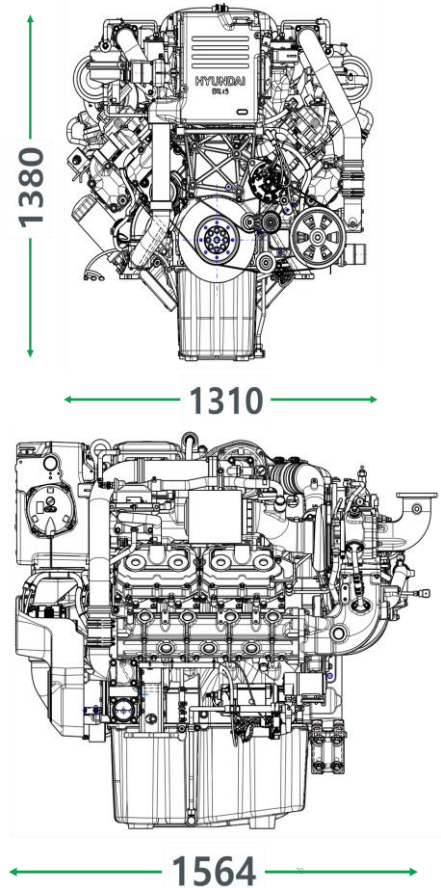

※ Specifications are subject to change without prior notice.

