

◎ Production Tolerance : ±5%

Intermittent rating kW(PS) / rpm	Max. torque N.m(kg.m) / rpm	Aftertreatment
199 (270) / 2500	780 (79.5) / 1400	None
199 (270) / 2500	863 (88) / 1400	

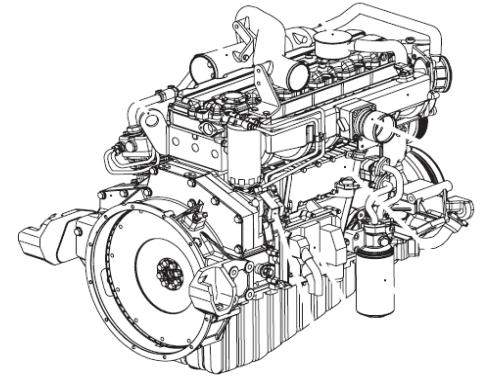

◎ General Specification

- Engine Model DL06
- Engine Type In-Line, 4 Cycle, Water Cooled
Thrbcharged & Intercooled
- Injection System Electronic Common Rail
- Cylinder Type Replaceable dry liner
- Number of Cylinders 6
- Bore x stroke 100 x 125 mm
- Displacement 5.9 L
- Compression ratio 17.4 : 1
- Firing order 1-5-3-6-2-4
- Dry weight 600 kg (Engine only)
- Dimension 1201 x 812 x 955 mm
- Rotation CCW viewed from Flywheel
- Breather System OVC / Mesh + Impactor (Single)
- No Load Max Engine Speed 2,750 +/- 20rpm
- No Load Min Engine Speed 650 +/- 25rpm
- Turbocharger Waste Gate Valve
- Air Compressor Capacity 305cc/rev

◎ Valve System

- Type Over Head Valve
- Number of Valve Intake 2, Exhaust 2 per Cylinder
- Valve Lashes at Cold Intake 0.3 mm
Exhaust 0.4 mm

◎ Fuel System

- Injection pump BOSCH CP3.3
- Governor E.C.U (BOSCH, EDC7UC31)
- Feed pump GEAR TYPE
- Injection nozzle Multi hole Type
- Fuel filter Full flow, Catridge Type
- Used fuel Diesel fuel oil

◎ Lubrication System

- Lub. Method Fully forced pressure feed Type
- Oil pump Gear Type driven by crankshaft
- Oil filter Full flow, Catridge Type
- Oil pan capacity High level 18 liters
Low level 12 liters
- Lub. Oil API CI-4 Grade, SAE 10W40

◎ Cooling System

- Cooling method Fresh water forced circulation
- Water capacity 11.5 liters (Engine only)
- Water pump Capacity 350 liters/min at 3,000rpm
- Thermostat Wax – Pellet Type

◎ Electrical System

- Alternator N/A (Vehicle Parts)
- Starting motor 24V x 4.5kW
- Battery Voltage 24V
- Battery Capacity 150AH x 2ea (recommended)

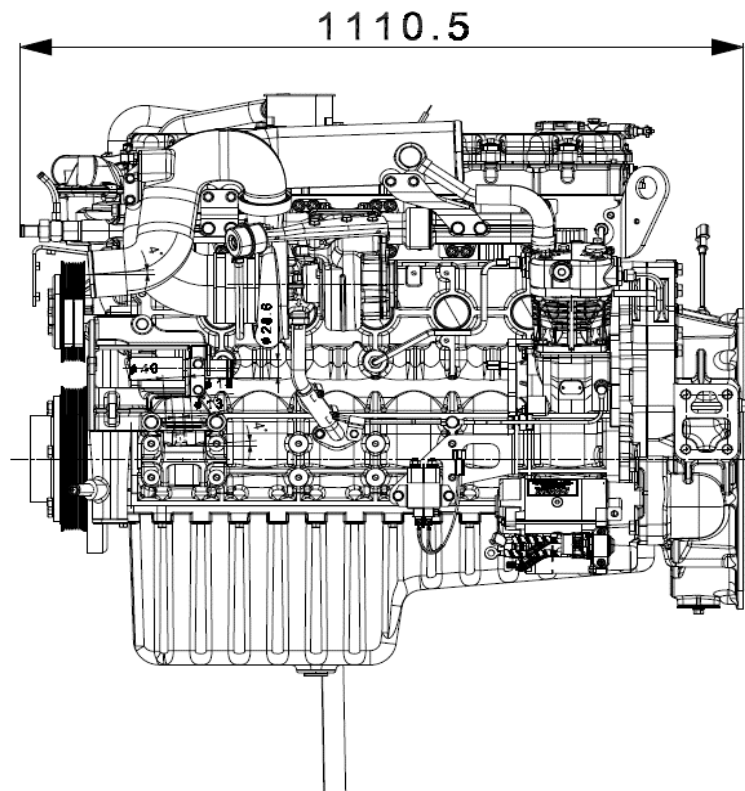
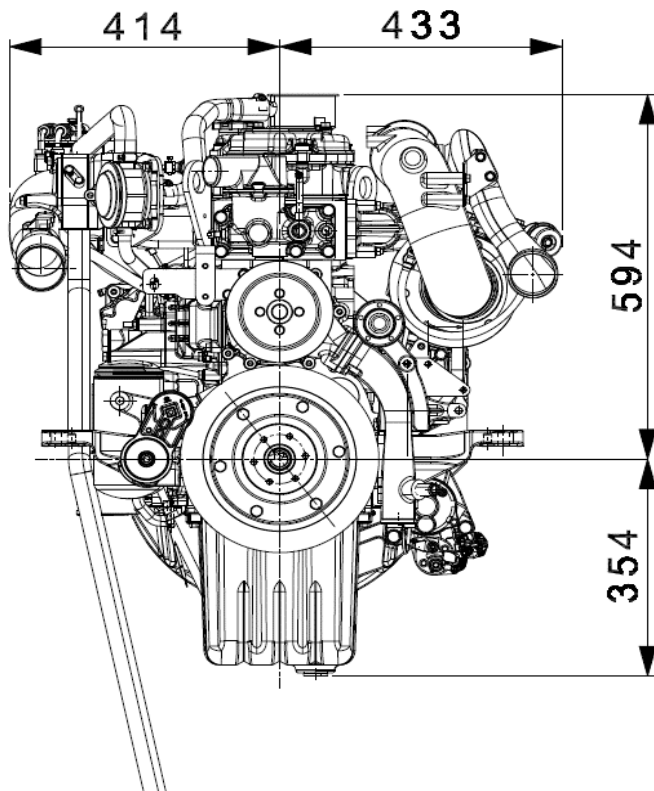

◎ Performance Curve

○ 199kW (270PS) / 79.5kg.m

○ 199kW (270PS) / 88kg.m

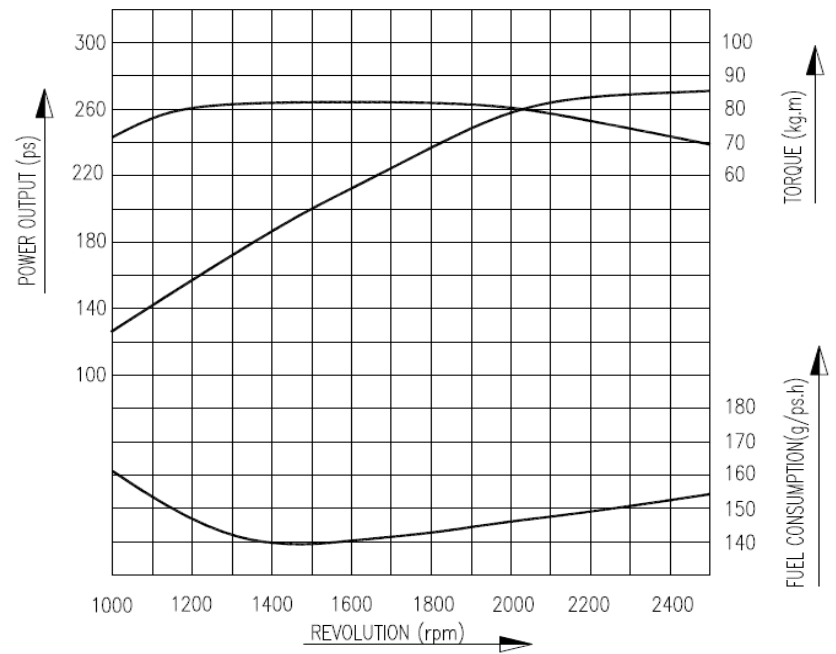
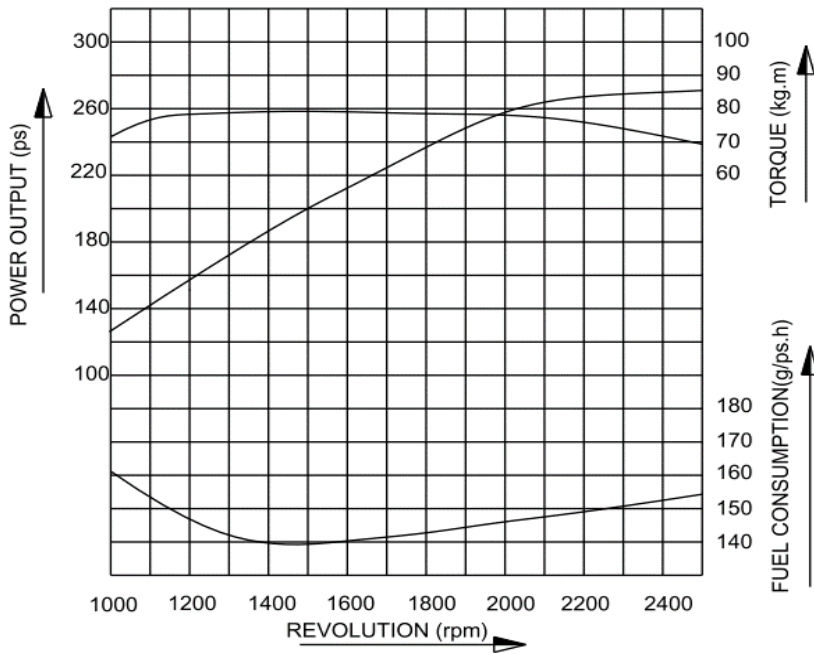

◎ Fuel Injection System

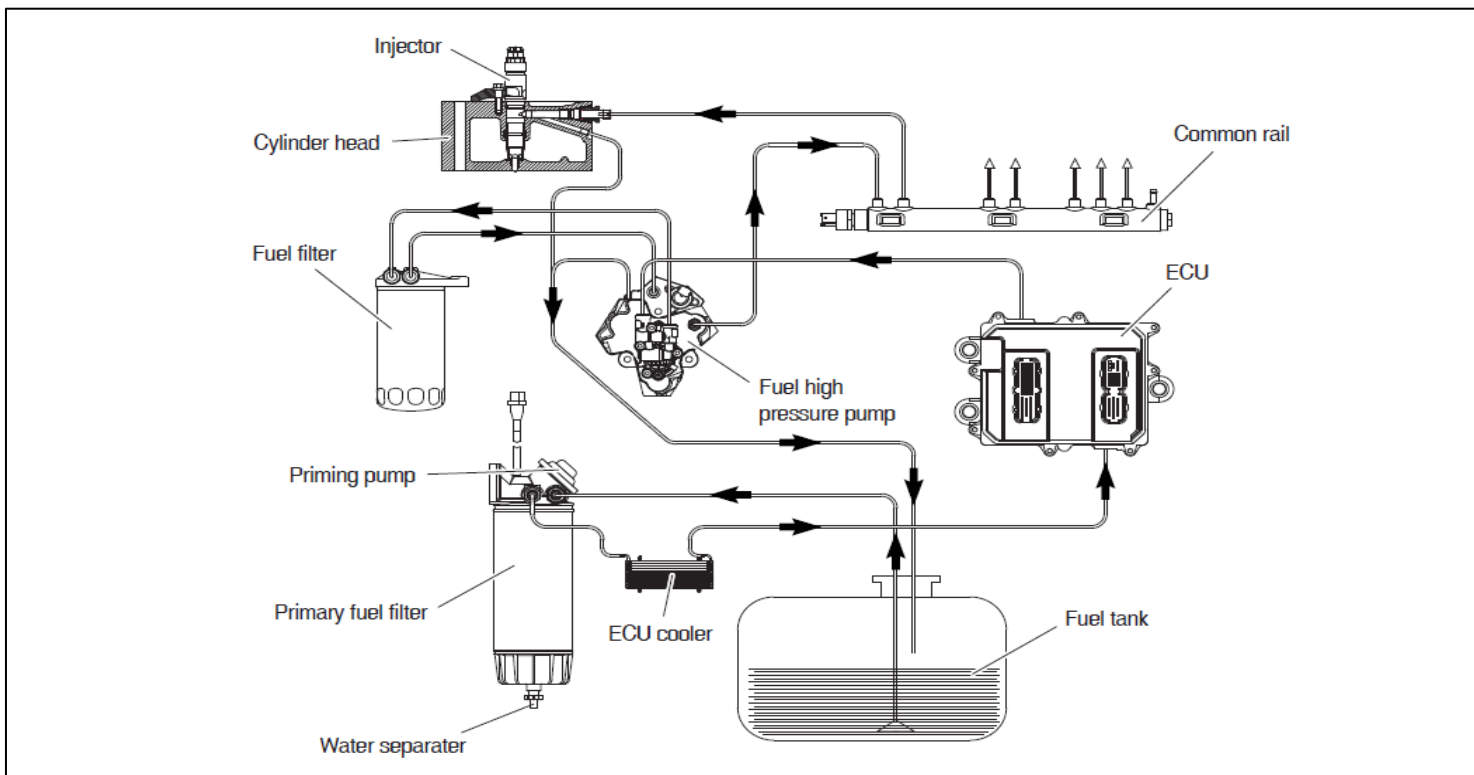

Head office

HD Hyundai Group's Global R&D Center 477,
Bundangsuseo-ro, Seongnam-si Gyeonggi-do,
Korea (13553)

Sales office (Engine)

11F, HD Hyundai Group's Global R&D Center