

◎ POWER RATING

Engine Speed rev/min	Type of Operation	Engine Power	
		kWm	PS
1800	Prime Power	410	557
	Standby Power	451	613
1500	Prime Power	350	476
	Standby Power	385	523

Note : -. The engine performance corresponds to ISO 3046, BS 5514 and DIN 6271.

* Without cooling fan, inter cooler inlet water temperature 32 °C

- Ratings are based on ISO 8528.

→ **Prime power** available at variable load. The permissible average power out put (during 24h period) shall not exceed 70% of the prime power rating. No overload is permitted.

→ **Standby power** available in the event of a main power network failure. No overload is permitted.



◎ MECHANICAL SYSTEM

○ Engine Type	V-type 4 cycle, water cooled Turbo charged & intercooled (water to air)
○ Combustion type	Stoichiometric, Premixed and spark ignited
○ Cylinder Type	Replaceable wet liner
○ Number of cylinders	12
○ Bore x stroke	128(5.04) x 142(5.59) mm(in.)
○ Displacement	21.927 (1,338.0) lit.(in ³)
○ Compression ratio	10.5 : 1
○ Firing order	1-12-5-8-3-10-6-7-2-11-4-9
○ Ignition timing	12° BTDC
○ Compression pressure	Above 28 kg/cm2(398 psi) at 200rpm
○ Dry weight (Engine)	Approx. 1,620 kg (3,572 lb)
○ Dimension (Engine) (LxWxH)	1,924 x 1,243 x 1,626 mm (75.7 x 48.9 x 64 in.)
○ Rotation	Counter clockwise viewed from Flywheel
○ Fly wheel housing	SAE NO.1
○ Fly wheel	Clutch NO.14

◎ MECHANISM

○ Type	Over head valve
○ Number of valve	Intake 1, exhaust 1 per cylinder
○ Valve lashes at cold	Intake 0.3mm (0.0118 in.) Exhaust 0.4mm (0.0157 in.)

◎ VALVE TIMING

	Opening	Close
○ Intake valve	24 deg. BTDC	36 deg. ABDC
○ Exhaust valve	63 deg. BBDC	27 deg. ATDC

◎ FUEL CONSUMPTION

○ Prime (Nm ³ /hr)	1,500 rpm	1,800 rpm
25%	25.6	37.5
50%	49.2	62.0
75%	73.4	89.4
90%	88.2	103.3
100%	95.2	107.2
○ Standby (Nm ³ /hr)	1,500 rpm	1,800 rpm
100%	105.6	112.2

◎ FUEL SYSTEM

○ Carburetor	Impco 200M Varifuel carburetor (2EA)
○ Gas regulator	Maxitrol RV61 (2EA)
○ Max. inlet pressure	1.0 psi at the engine inlet

◎ LUBRICATION SYSTEM

○ Lub. Method	Fully forced pressure feed type
○ Oil pump	Gear type driven by crankshaft
○ Oil filter	Full flow, cartridge type
○ Oil pan capacity	High level 40 liters (10.6 gal.) Low level 33 liters (8.7 gal.)
○ Lub. Oil	Refer to Operation Manual Low ash type(0.5wt%) natural gas engine oil API service grade CD or higher SAE 15W-40

◎ COOLING SYSTEM

○ Cooling method	Fresh water forced circulation
○ Water capacity	44 liters (11.62 gal.) (Engine only)
○ Pressure system	Max. 0.5 kg/cm ² (7.1 psi)
○ Water pump	Centrifugal type driven by belt
○ Cooling fan	Blower, 1070mm diameter, 12 blades Plastic
○ Loss power of fan	43PS (32kW) @ Eng. Speed 1,500 rpm 65PS (48kW) @ Eng. Speed 1,800 rpm
○ Thermostat	Wax – pellet type Opening temp. 71°C Full open temp. 85°C

◎ ELECTRICAL SYSTEM

○ Charging generator	28.5V x 45A alternator
○ Voltage regulator	Built-in type IC regulator
○ Starting motor	24V x 7.0kW
○ Battery Voltage	24V
○ Battery Capacity	200 AH (recommended)
○ Ignition controller	12 or 24V DC (min 8V DC at start, 32V DC max)

◎ IGNITION SYSTEM

○ Spark plug	NGK IFR7B-D, 0.4mm air gap Champion RC78PYP, 0.38mm air gap
○ Ignition controller	Altronic CPU-95 unit (24V DC)
○ Ignition coil	Altronic 501 061 blue epoxy individual coil
○ Trigger system	Magnetic pick-up sensor and trigger wheel and Hall-effect (0.5/ 0.5/ 1.0mm air gap)

◎ ENGINEERING DATA

○ Water flow	550 liters/min @1,500 rpm 640 liters/min @1,800 rpm
○ Heat rejection to coolant	90.1 kcal/sec @1,500 rpm 108.2 kcal/sec @1,800 rpm
○ Heat rejection to CAC	6.1 kcal/sec @1,500 rpm 9.1 kcal/sec @1,800 rpm
○ Inter cooler water flow	290 liters/min @1,500 rpm 340 liters/min @1,800 rpm
○ Air flow	29.6 m ³ /min @1,500 rpm 35.5 m ³ /min @1,800 rpm
○ Exhaust gas flow	47.8 m ³ /min @1,500 rpm 57.4 m ³ /min @1,800 rpm
○ Exhaust gas temp.	490 °C @1,500 rpm 515 °C @1,800 rpm
○ Radiator air flow	670 m ³ /min @1,500 rpm, 0.7kPa 720 m ³ /min @1,800 rpm, 1kPa
○ Max. permissible restrictions	
-Intake system	220 mmH ₂ O initial 635 mmH ₂ O final
-Exhaust system	600 mmH ₂ O max.
○ Altitude Capability	1,500 m

◆ CONVERSION TABLE

in. = mm x 0.0394	lb/ft = N.m x 0.737
PS = kW x 1.3596	U.S. gal = lit. x 0.264
psi = kg/cm ² x 14.2233	kW = 0.2388 kcal/s
in ³ = lit. x 61.02	lb/PS.h = g/kW.h x 0.00162
hp = PS x 0.98635	cfm = m ³ /min x 35.336
lb = kg x 2.20462	Nm ³ = SCF × 0.0283
Kg/hr = Nm ³ /hr × 0.732 (natural gas)	
Btu/ft ³ = MJ/m ³ × 26.8392 (natural gas)	
kPa = 101.97 mmH ₂ O = 0.01 bar	

© Dimensions : Engine

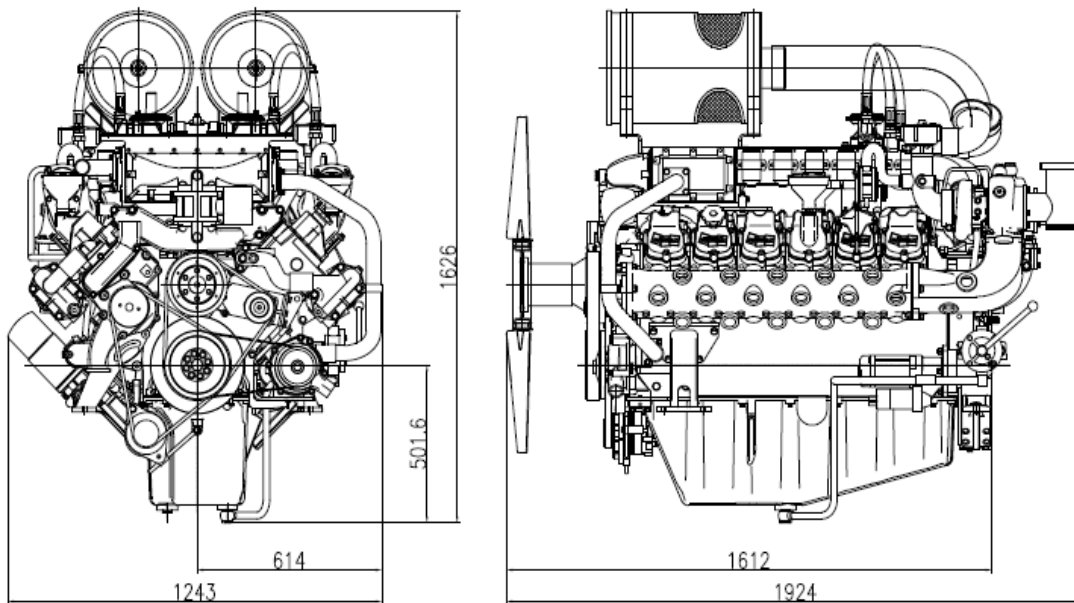

© Dimensions : Gen-pack

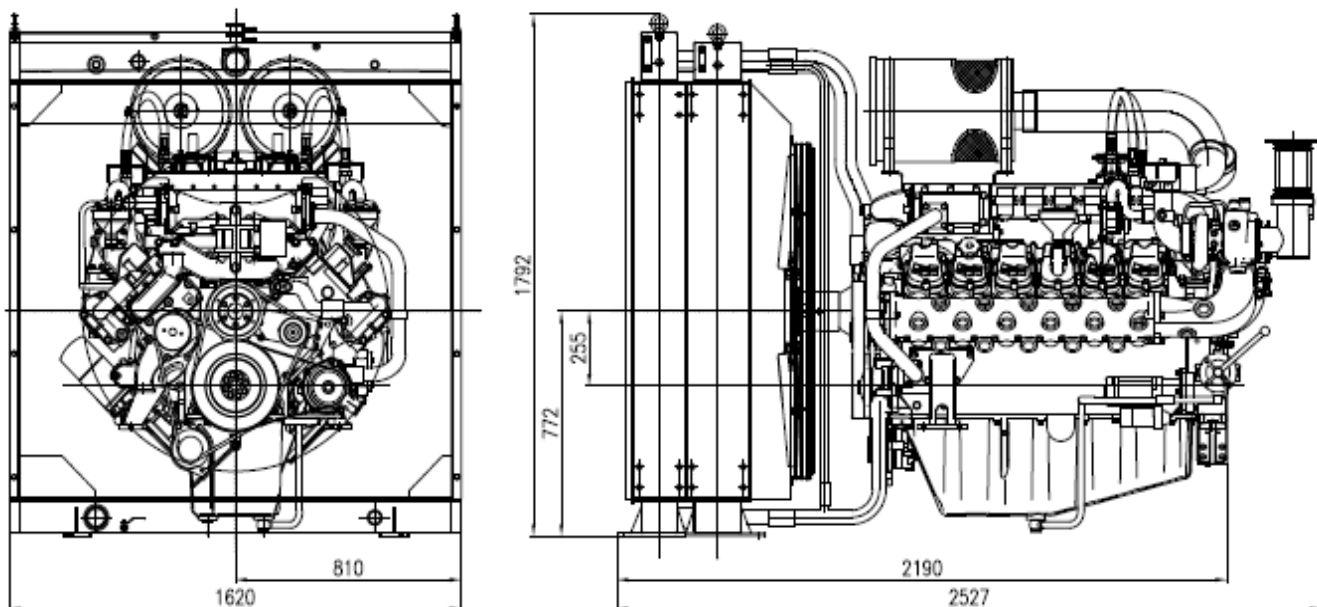

Head office

HD Hyundai Group's Global R&D Center 477,
Bundangsuseo-ro, Seongnam-si Gyeonggi-do,
Korea (13553)

Sales office (Engine)

11F, HD Hyundai Group's Global R&D Center