

### POWER RATING

Production tolerance : ± 3%

MODEL	CONDITIONS	POWER	rpm	Base Engine
L086TIH	HEAVY DUTY	285PS (210kW)	2,100	D1146TIB
L086TIM	MEDIUM DUTY	315PS (232kW)	2,300	
L086TIL	LIGHT DUTY	360PS (265kW)	2,500	

**Note : 1)** No reduction in rating for intake air temperature is up to 45 °C (318K) and sea water temperature is up to 32 °C (305K) , relative humidity is up to 60 % all data are based on operation to ISO 3046.

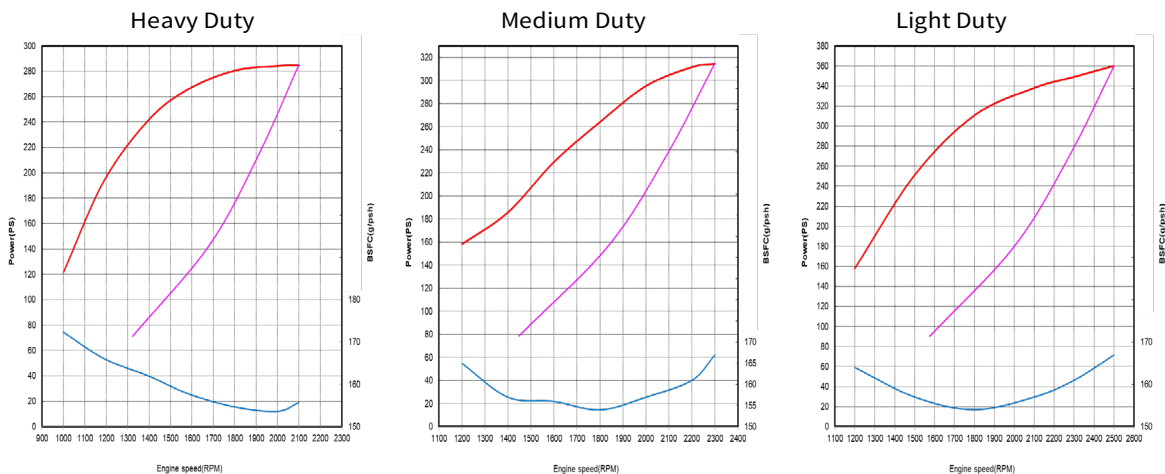
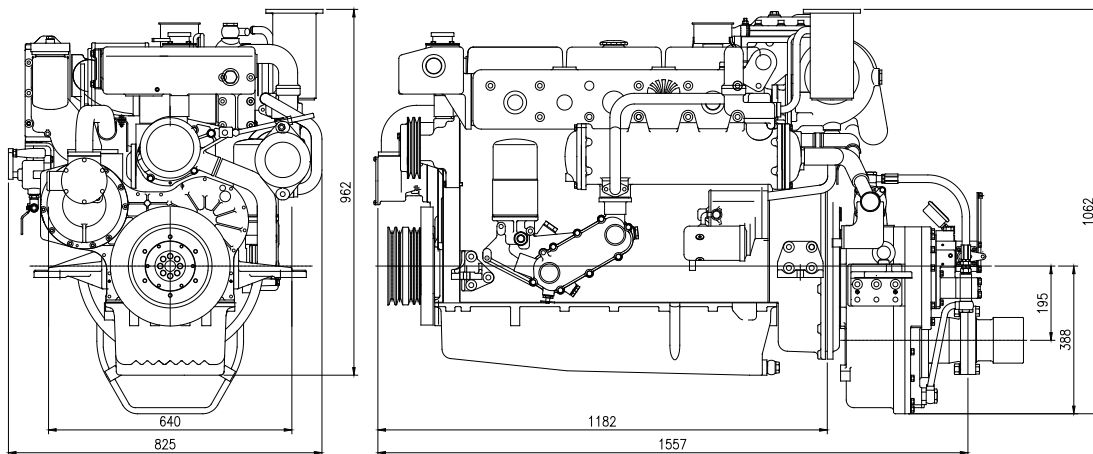

- **Heavy Duty :** Operation hours are unlimited per year, at average load is up to 90 % ,  
At full load is up to 80 %  
Typical gearbox ratio: 2.5 ~ 6  
(Fishing trawler, Tug boat, Pushing vessel, Cargo boat, Freighter, Ferry)
- **Medium Duty :** Operation hours are up to 3,000 per year, at average load is up to 70 %  
At full load is (up to 30 % / 4hrs per 12 hour operation period)  
Typical gearbox ratio: 2 ~ 3.5  
(Fishing boat, Pilot boat, Escort boat, Passenger boat, Ferry, Cruising vessel)
- **Light Duty :** Operation hours are up to 1,000 per year, at average load is up to 50 %  
At full load is (up to 20 % / 2hrs per 12 hour operation period)

Typical gearbox ratio: 1 ~ 2.5

(Light weight fishing boat, Yacht, Coastguard boat, Fast boat, Fire pump)

Engine Specification				
Model	Units	L086TIH	L086TIM	L086TIL
Engine type		4 cycle, In line, direct- injection, water cooled with wet turbo charger & inter-cooler		
Rating output (B.H.P)	PS(kW)/rpm	285(210)/2,100	315(232)/2,300	360(265)/2,500
Displacement	cc	8,071		
Cylinder number - bore(φ) x stroke	mm	6 - φ111 x 139		
Valve clearance at cold	In / Ex	0.3 / 0.3		
Low idling rpm	rpm	750 ± 25		
No load max. rpm	rpm	below 2,310	below 2,530	below 2,750
Mean effective pressure	kg/cm <sup>2</sup>	15.14	14.55	16.06
Mean piston speed	m/sec.	9.73	10.66	11.58
Compression ratio		16.7 : 1		15.3:1
Firing order		1 - 5 - 3 - 6 - 2 - 4		
Compression pressure	at 200 rpm	kg/cm <sup>2</sup> 28 (Initial condition)		
Governor type of injection pump		Mechanical all speed (R.S.V)		
Fuel consumption	g/PS.h	156	163	167
	lit / h	53	62	72
Injection timing (B.T.D.C)	deg	15° ± 1°	15° ± 1°	15° ± 1°
Fuel inj. Nozzle opening pressure	kg/cm <sup>2</sup>	214		
Starting system		Electric Starting by starter motor		
Starter motor capacity	V- kW	24 - 4.5		
Alternator capacity	V- A	24 - 80		
Battery	V- Ah	24 - 100		
Cooling system		Indirect sea water cooling with heat exchanger		
Cooling water capacity	Max. / Min.	lit 27 / 25		
Fresh water pump type		Centrifugal type, driven by V- belt		
Sea water pump type		Rubber impeller type driven by gear		
Lubricating oil (Engine)	pan capacity	lit Max : 23, Min : 17 ( Engine total : 25)		
	pressure	kg/cm <sup>2</sup> Full : 3.5, Idle : 1.2		
Marine gear	Model	DMT 110A ( Dong - I )		
	Gear ratio	1.77 2.09 2.42 2.82 3.19		
Direction of revolution	crankshaft	Counter clockwise viewed from stern side		
	propeller	Clockwise viewed from stern side		
Engine size (L x W x H)	without M/G	mm 1,182 x 825 x 962		
	with M. gear	mm 1,552 x 825 x 1,062		
Engine dry weight	without M/G	kg 790		
	with M. gear	kg 1,015		

psi = kg/cm<sup>2</sup> x 14.22  
 lb/ft. = N.m x 0.737  
 kW = 0.2388 kcal/s

lb = kg x 2.205  
 lb/PS.h = g/kW.h x 0.00162  
 cfm = m<sup>3</sup>/min x 35.3

hp = PS x 0.98635  
 U.S gal. = liter x 0.264



### Head office

HD Hyundai Group's Global R&D Center 477,  
 Bundangsuseo-ro, Seongnam-si Gyeonggi-do,  
 Korea (13553)

### Sales office (Engine)

11F, HD Hyundai Group's Global R&D Center

※ Specifications are subject to change without prior notice.