

HYUNDAI GV222CA



50/60Hz
MULTI
FREQUENCY
GENERATOR



GENERATOR



Description

- HD Construction Equipment introduced new gaseous generator electronic engines GV222 C-Series.
- When compared to other engines of equivalent capacity, it displays a higher output, better fuel efficiency, higher safety, and easier maintenance.
- LPG fuel ready and Hydrogen fuel blending capable (Up to 30%)

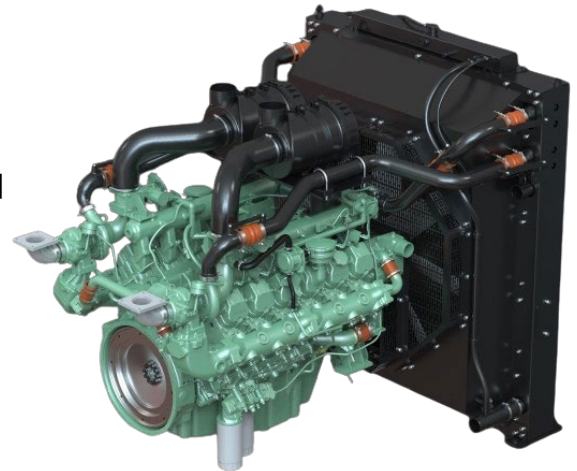

Features

[High Power & Economy]

- High performance & Low fuel/oil consumption
- 50/60 Hz switchable without Power De-rating
- G3 Class(ISO 8528-5)

[High Durability]

- High strength design for main structure parts
- Higher warranty period through sufficient verification

[Convenience & Safety]

- Oil maintenance interval: 500hrs without replenishment
- Auto tensioning belt drive system
- Radiator to cover a wide range of usage condition
- Specs for both Natural Gas and Biogas are available
- Safety guard for hazard parts
- Meet REACH & RoHS regulations

Power

	50 Hz / 1500 rpm									60 Hz / 1800 rpm								
	Standby			Prime/DCP			Continuous			Standby			Prime/DCP			Continuous		
	kWm	kWe	kVA	kWm	kWe	kVA	kWm	kWe	kVA	kWm	kWe	kVA	kWm	kWe	kVA	kWm	kWe	kVA
Natural Gas	405	363	454	368	328	410	294	258	323	470	409	511	427	369	461	342	288	360
LPG	275	240	300	250	216	270	200	169	211	310	258	323	282	232	290	226	179	224

Generator efficiency (typical) : 94.5%

kWm= kiloWatt mechanical, Gross power; kWe= kiloWatt electrical = kWm x Generator eff.; kVA= kiloVoltAmpere calculations based on a 0.8 power factor = kWe/0.8



General Data

Type	Natural gas, water cooled, Turbo charged & intercooled
Bore	128 mm
Stroke	142 mm
Displacement	21.9 L
Cylinders and Arrangement	Cast iron, 12 cylinders, V Type(90°)
Battery charging alternator	24V x 45A alternator
Starting voltage	24V
Fuel System	Woodward Electric Fuel Regulator, Controlled by ECU
Used fuel	Pipeline Gas(NG), Wellhead Gas, Bio-Gas, Propane
Lube oil filter type(s)	Full flow, cartridge type
Lube oil capacity(l)	-
Flywheel dimensions	Clutch No. 14 M

Coolpac Data

Cooling method	Jacket Water and Charge Air Cooled	
Cooling ratio	50% ethylene glycol; 50% water	
Water capacity (L)	with radiator	103 liters
	without radiator	53 liters
Fan power (kWm)	21 kW(50Hz), 37 kW(60Hz)	
Cooling system air flow(m ³ /s)	21.1(50Hz), 25.2(60Hz)	

Fuel Consumption

Fuel Consumption 1500 rpm (50Hz)

%	kWm	BHP	kg/hr
Standby Power			
100	405.0	543.1	85.0
Prime Power			
100	368.0	493.5	77.0
75	276.0	370.1	60.0
50	184.0	246.7	43.0
25	92.0	123.4	28.0
Continuous Power			
100	294.0	394.3	65.0

Fuel Consumption 1800 rpm (60Hz)

%	kWm	BHP	kg/hr
Standby Power			
100	470.0	630.3	100.0
Prime Power			
100	427.0	572.6	91.0
75	320.3	429.5	71.0
50	213.5	286.3	52.0
25	106.8	143.2	33.0
Continuous Power			
100	342.0	458.6	76.0



Dimensions

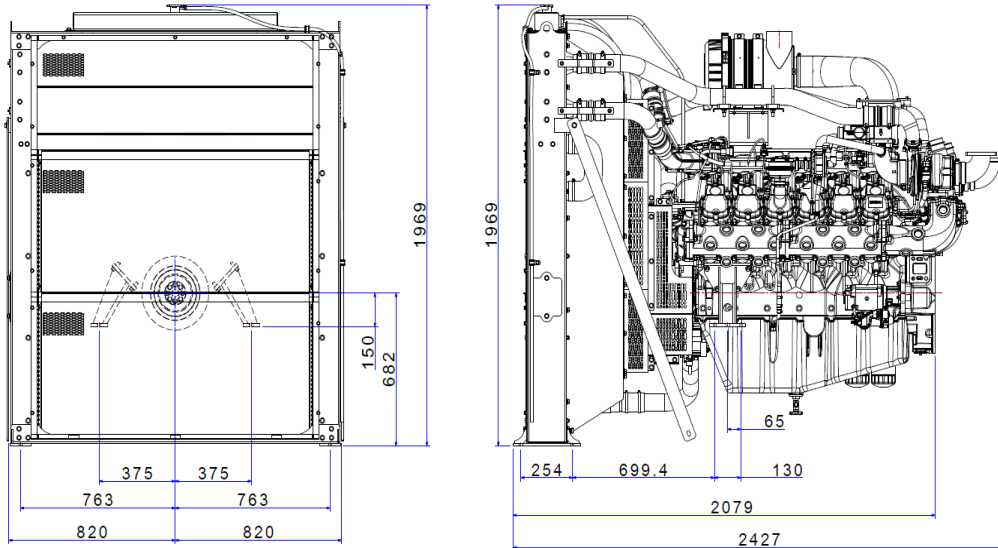

Weights and Dimensions (G-Pack)

Length mm	Width mm	Height mm	Weight (dry) kg
2,427	1,640	1,969	1,982

Power Rating Guide

The power ratings of Emergency Standby and Prime are in accordance with ISO 8528. Fuel Stop power in accordance with ISO 3046. Electric power (kWe) must be considered cooling fan loss, alternator efficiency, altitude derating and ambient temperature.

ESP(STANDBY POWER) is applicable for supplying emergency power for the duration of the utility power outage. No overload capability is available for this rating. A standby rated engine should be sized for a maximum of an 80% average load factor and 200 hours of operation per year. This includes less than 25 hours per year at the Standby Power rating.

PRP(PRIME POWER) is available for an unlimited number of hours per year in variable load application. Variable load should not exceed a 80% average of the Prime Power rating during any operating period of 24 hours.

The Total operating time at 100% Prime Power shall not exceed 500 hours per year.

A 10% overload capability is available for a period of 1 hour within a 12 hours period of operation.

Total operating time at the 10% overload power shall not exceed 25 hours per year.

COP(CONTINUOUS POWER) is defined as being the maximum power which the generating set is capable of delivering continuously whilst supplying a constant electrical load when operated for an unlimited number of hours per year under the agreed operating conditions with the maintenance intervals and procedures being carried out as prescribed by the manufacturer.

DCP(DATA CENTRE POWER) is available for variable or continuous electrical loads in a data centre application.

Up to 100 percent load factor is permitted for unlimited time. DCP power definition relies on ISO 8528-1 2018 standard to be followed by generator set manufacturer, and will support Tier I to Tier IV classifications of data centres as per UPTIME institute guidelines. This definition is only back up a reliable utility. Continuous operation at load is available as after approval of Engine manufacturer (HCE).

※ Specifications are subject to change without prior notice.

