

◎ **Production Tolerance : ±5%**

Intermittent rating kW(HP) / rpm	Max. torque N.m(kg.m) / rpm	Aftertreatment
221 (300) / 2200	1127 (115) / 1200	None

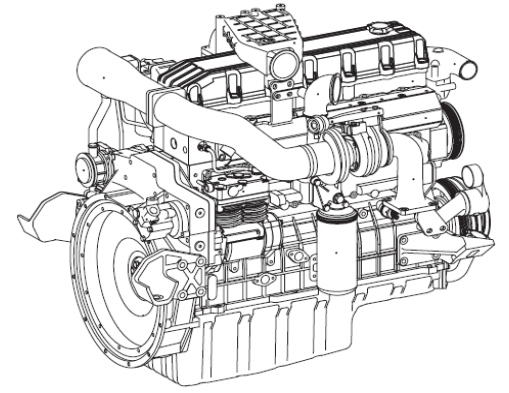

◎ **General Specification**

- Engine Model DL08
- Engine Type In-Line, 4 Cycle, Water Cooled  
Thrbcharged & Intercooled
- Injection System Electronic Common Rail
- Cylinder Type Replaceable dry liner
- Number of Cylinders 6
- Bore x stroke 108 x 139 mm
- Displacement 7.6 L
- Compression ratio 16.5 : 1
- Firing order 1-5-3-6-2-4
- Dry weight 836 kg (Engine only)
- Dimension 1214 x 801 x 1085 mm
- Rotation CCW viewed from Flywheel
- Breather System OVC / Mesh + Impactor (Single)
- No Load Max Engine Speed 2,420 +10/-50rpm
- No Load Min Engine Speed 600 +/- 10rpm
- Flywheel Housing SAE1
- Flywheel Size OEM FLYWHL MTG PCD
- Turbocharger Waste Gate Valve
- Air Compressor Capacity 440cc/rev

◎ **Valve System**

- Type Over Head Valve
- Number of Valve Intake 2, Exhaust 2 per Cylinder
- Valve Lashes at Cold Intake 0.3 mm  
Exhaust 0.4 mm

◎ **Fuel System**

- Injection pump BOSCH CP3.3
- Governor E.C.U (BOSCH, EDC7C1)
- Feed pump GEAR TYPE
- Injection nozzle Multi hole Type
- Fuel filter Full flow, Catridge Type
- Used fuel Diesel fuel oil

◎ **Lubrication System**

- Lub. Method Fully forced pressure feed Type
- Oil pump Gear Type driven by crankshaft
- Oil filter Full flow, Catridge Type
- Oil pan capacity High level 28 liters  
Low level 22 liters
- Lub. Oil API CI-4 Grade, SAE 10W40

◎ **Cooling System**

- Cooling method Fresh water forced circulation
- Water capacity 18.2 liters (Engine only)
- Water pump Capacity 400 liters/min at 3,055rpm
- Thermostat Wax – Pellet Type

◎ **Electrical System**

- Alternator N/A (Vehicle Parts)
- Starting motor 24V x 6.0kW
- Battery Voltage 24V
- Battery Capacity 150AH x 2ea (recommended)

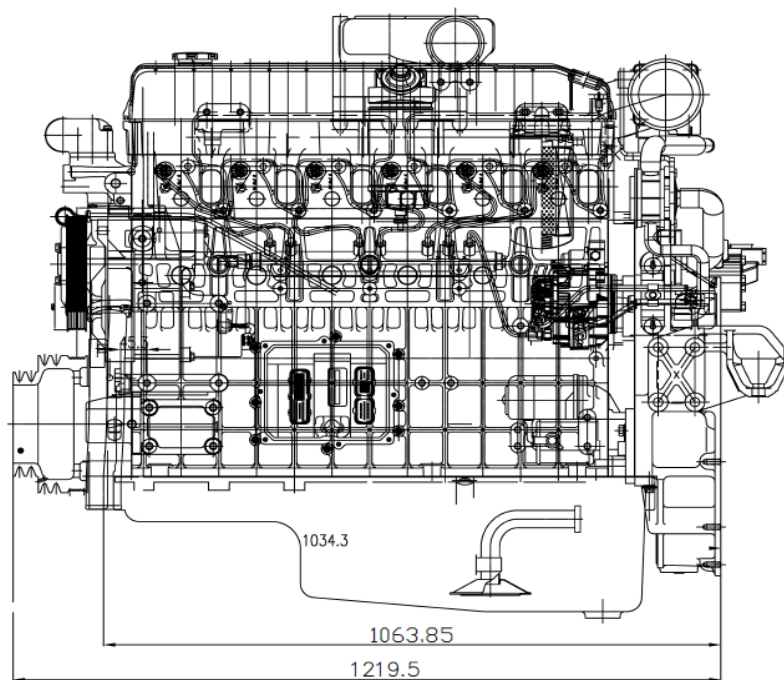
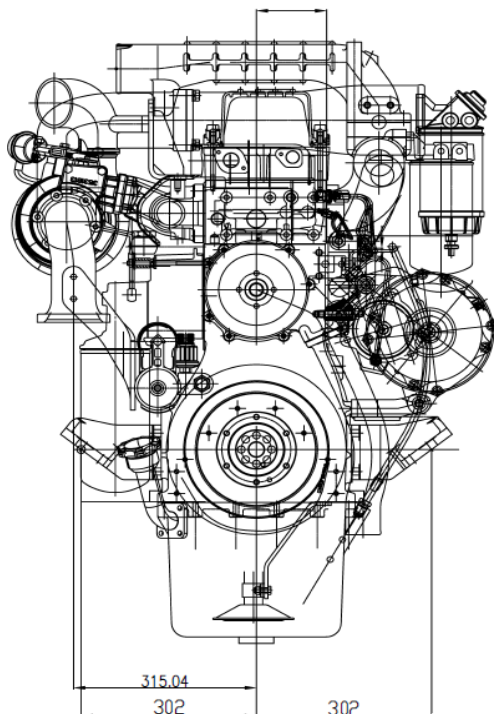

## ◎ Performance Curve

○ 221kW (300PS) / 115kg.m

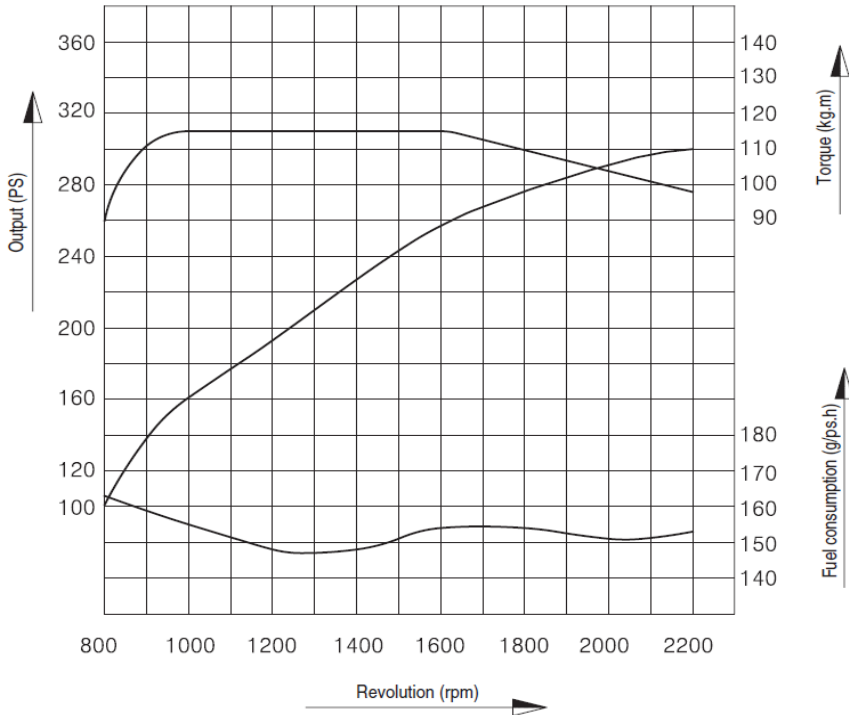

## ◎ Fuel Injection System

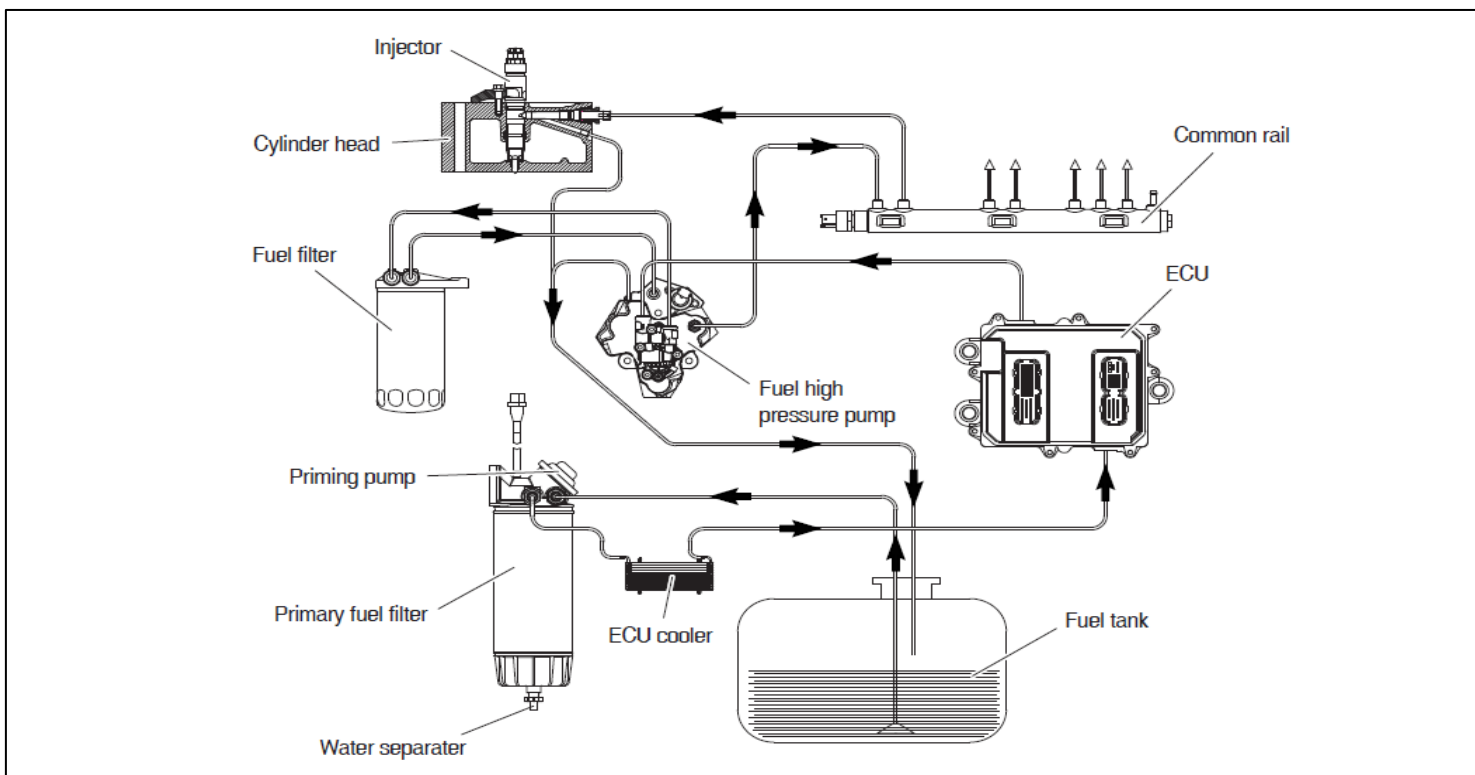

### Head office

HD Hyundai Group's Global R&D Center 477,  
Bundangsuseo-ro, Seongnam-si Gyeonggi-do,  
Korea (13553)

### Sales office (Engine)

11F, HD Hyundai Group's Global R&D Center