

◎ Production tolerance : ±5%

Intermittent rating kW(PS) / rpm	Max. torque N.m(kg.m) / rpm
287 (390) / 1900	1569 (160) / 1200
309 (420) / 1900	1833 (187) / 1200

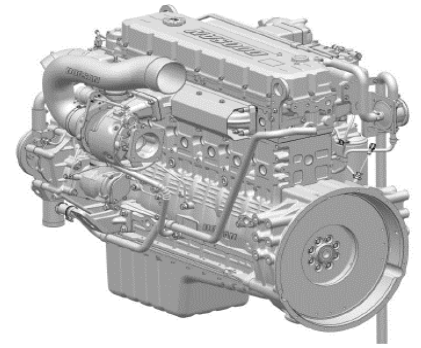

◎ MECHANICAL SYSTEM

- Engine Model DX12TIS
- Engine Type In-line Type 4 cycle, water cooled
Turbocharged & Intercooled
- Combustion Type Direct injection
- Cylinder Type Replaceable dry liner
- Number of cylinders 6
- Bore x stroke 123 x 155 mm
- Displacement 11.051(674.37) lit.(in³)
- Compression ratio 17.0 : 1
- Firing order 1-5-3-6-2-4
- Injection timing BTDC 12degCA
- Dry weight 1,000 kg
- Dimension 1,318 x 973 x 1,116 mm
- Rotation Counter clockwise viewed from Flywheel
- No Load Max Engine Speed 2,100 +/- 50 rpm
- No Load Min Engine Speed 600 +/- 50 rpm
- Air Comp. Capacity 354 cc/rev (Single)

◎ MECHANISM

- Type Over head valve
- Number of valve Intake 2, exhaust 2 per cylinder
- Valve lashes at cold Intake 0.4mm
Exhaust 0.5mm

◎ COOLING SYSTEM

- Cooling method Fresh water forced circulation
- Water capacity (Engine Only) 23 liters
- Water pump Centrifugal Type driven by Gear
- Water pump Capacity 350 liters/min at 1,900 rpm
- Thermostat Wax – pellet Type
Opening temp. 83°C or 71°C
Full open temp. 95°C or 85°C

◎ FUEL SYSTEM

- Injection pump WEIFU P8500
- Feed pump Plunger Type
- Injection nozzle DLLA P Type
- Fuel filter Full flow, Cartridge Type
- Used fuel Diesel fuel oil

◎ LUBRICATION SYSTEM

- Lub. Method Fully forced pressure feed Type
- Oil pump Gear Type driven by crankshaft
- Oil filter Full flow, Cartridge Type
- Oil pan capacity High level 26 liters
Low level 16 liters
- Lub. Oil Refer to Operation Manual

◎ VALVE TIMING

- | | Opening | Close |
|-----------------|--------------|--------------|
| ○ Intake valve | 24 deg. BTDC | 38 deg. ABDC |
| ○ Exhaust valve | 62 deg. BBDC | 25 deg. ATDC |

◎ ELECTRICAL SYSTEM

- Starting motor 24V x 6kW
- Battery Voltage 24V
- Battery Capacity 150 AH x 2EA (Recommended)

◆ CONVERSION TABLE

- | | |
|------------------------------------|------------------------------------|
| in. = mm x 0.0394 | lb/ft = N.m x 0.737 |
| PS = kW x 1.3596 | U.S. gal = lit. x 0.264 |
| psi = kg/cm ² x 14.2233 | kW = 0.2388 kcal/s |
| in ³ = lit. x 61.02 | cfm = m ³ /min x 35.336 |
| hp = PS x 0.98635 | lb = kg x 2.20462 |

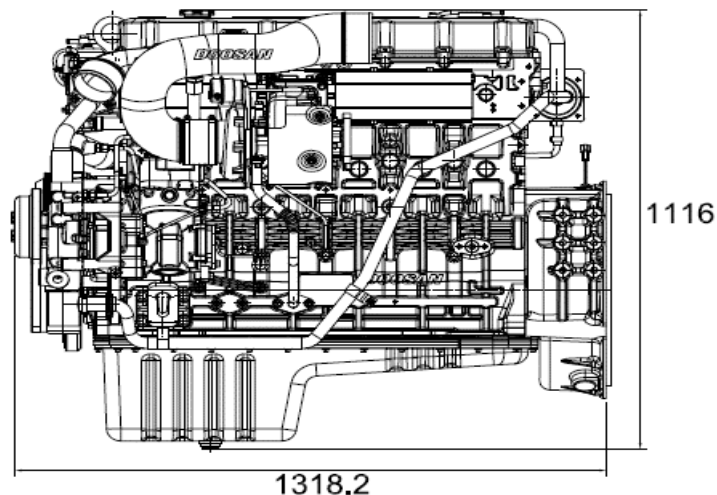
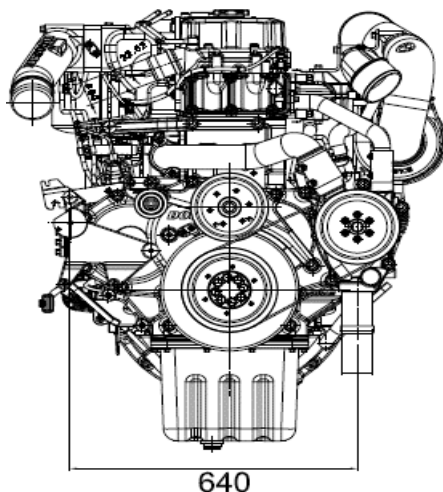

◎ PERFORMANCE CURVE

○ 287kW (390PS) / 160kg.m

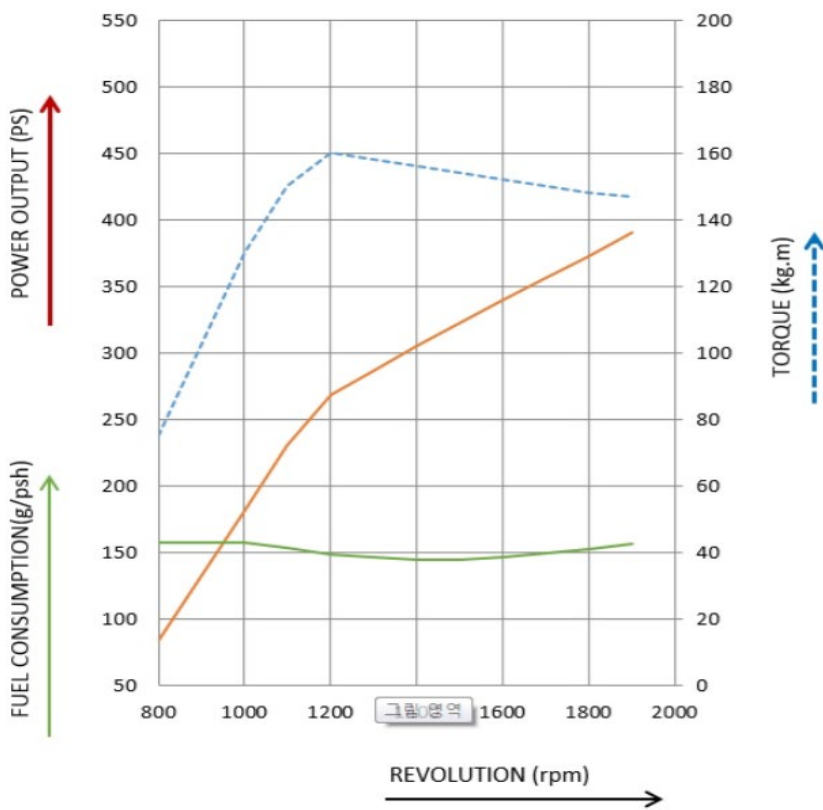

○ 309kW (420PS) / 187kg.m

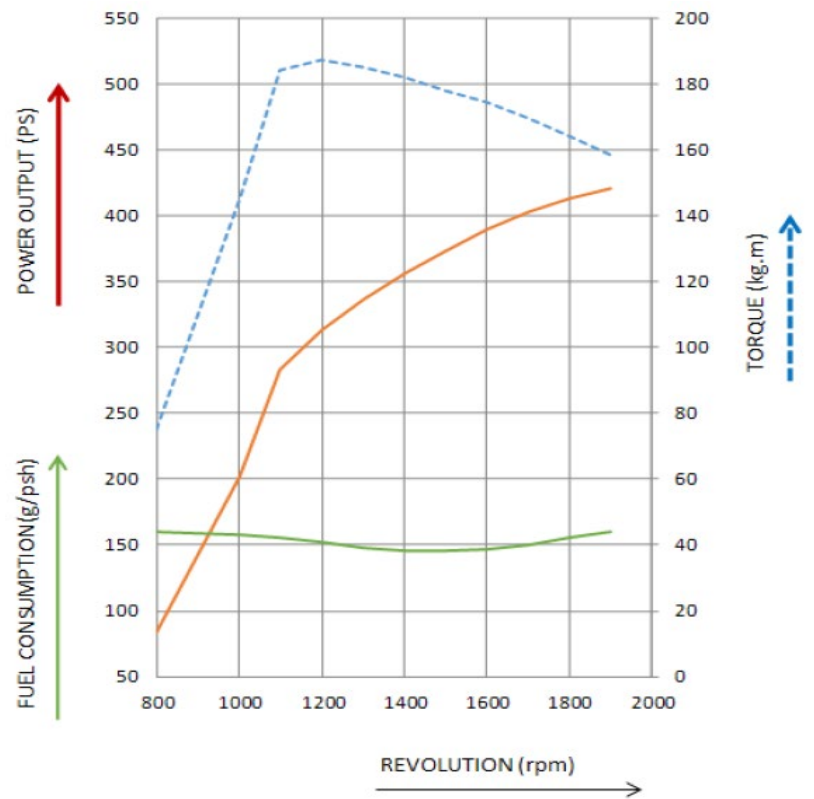

Head office

HD Hyundai Group's Global R&D Center 477,
Bundangsuseo-ro, Seongnam-si Gyeonggi-do,
Korea (13553)

Sales office (Engine)

11F, HD Hyundai Group's Global R&D Center

※ Specifications are subject to change without prior notice