

# HYUNDAI

# 4AD086C



MARINE

## Power Rating

Conditions	Model	Max. Power		rpm	Emission
		kW	PS		
50Hz	4AD086CA(F)	199	271	1500	IMO Tier II/III EPA Tier 3
60Hz	4AD086CA(S)	235	320	1800	
	4AD086CB(S)	200	272	1800	

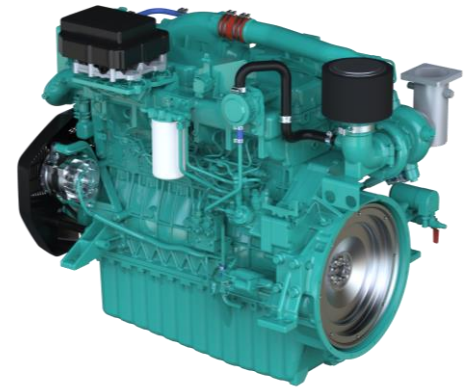

\* No reduction in rating for intake air temperature is up to 45°C (318K) and sea water temperature is up to 32°C (305K), relative humidity is up to 60%

\* All data are based on operation to ISO 3046. Performance tolerance of ±3%

## Key Features and Benefit

### High Performance

- Advanced fuel injection system with common rail
- Compliance with emission regulation (IMO Tier II/III, EPA Tier 3)
- High-efficiency SCR
- Smoke reduction
- Increased durability of key components

### Convenience

- Auto tensioner
- Turning device
- Electrical oil drain pump
- CCV for engine room cleanliness

### Economical

- Decreasing fuel consumption to average 5% by downsizing
- Increased oil & filter replacement cycle (250hr → 500hr)

### Warranty

- Maximum 3 years warranty provided through extended warranty option

### Engine Specifications

Engine Model	4AD086C (DL08)
Cylinders and Arrangement	6-cylinder / L type
Bore x Stroke	108 x 139 mm
Displacement	7.6 liter
Compression Ratio	16.0 : 1
Firing Order	1-5-3-6-2-4
Direction of Revolution	Counterclockwise viewed from Flywheel
Fuel system	Common rail controlled by ECU
Starting system	Electric starting by starter motor
Starter motor capacity	24V - 6.0A
Alternator capacity	24V - 80Ah
Battery	24V - 200Ah
Aspiration	Water cooled with turbo charger & Inter-cooler
Flywheel Housing	SAE #2 (FW: 11.5")
Cooling system	Indirect sea water cooling with heat exchanger / Keel Cooling
Cooling water capacity	28 liter
Fresh water pump type	Centrifugal (Pulley type)
Sea water pump type	Rubber Impeller
After Treatment System	IMO Tier-II / EPA Tier 3: Not Required IMO Tier-III : SCR
Lubricant Oil	Oil pan capacity Max : 47 liter, Min : 23 liter Pressure Full load : 3.0, Idle : 1.0 (kg /cm <sup>2</sup> )
Dimension (L x W x H)	1394 x 882 x 1220 mm
Dry Weight	920 kg

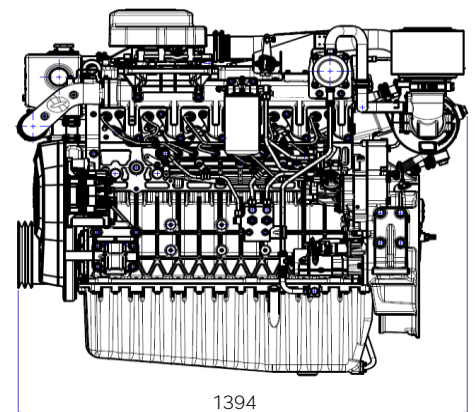
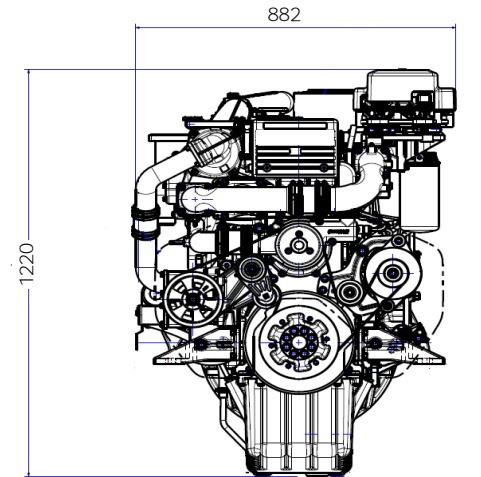

※ Specifications are subject to change without prior notice.

