

◎ Production Tolerance : ±5%

Intermittent rating kW(HP) / rpm	Max. torque N.m(kg.m) / rpm	Aftertreatment
184 (250) / 2500	882 (90) / 1400	SCR
199 (270) / 2500	980 (100) / 1400	

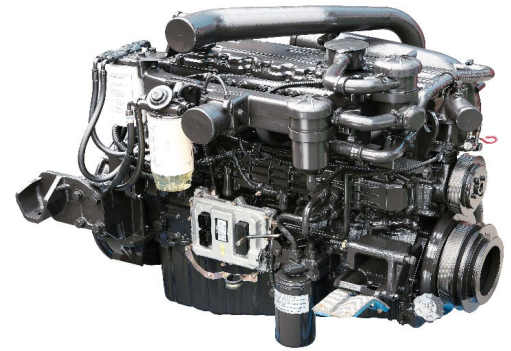

◎ General Specification

- Engine Model DL06S
- Engine Type In-line, 4 Cycle, Water Cooled
Turbocharged & Intercooled
- Injection System Electronic Common Rail
- Cylinder Type Replaceable dry liner
- Number of Cylinders 6
- Bore x stroke 100 x 125 mm
- Displacement 5.9 L
- Compression ratio 17.4 : 1
- Firing order 1-5-3-6-2-4
- Dry weight 606kg (Engine only)
- Dimension 1106 x 973 x 827 mm
- Rotation CCW viewed from Flywheel
- Breather System OCV
- No Load Max Engine Speed 2,725 +/-25rpm
- No Load Min Engine Speed 600 +/- 25rpm
- Flywheel Housing OEM FLYWHL MTG PCD
- Flywheel Size 17 inch Push
- Turbocharger Waste Gate Valve
- Air Compressor Capacity 305cc/rev

◎ Valve System

- Type Over Head Valve
- Number of Valve Intake 2, Exhaust 2 per Cylinder
- Valve Lashes at Cold Intake 0.3mm
Exhaust 0.4mm

◎ Fuel System

- Injection pump BOSCH CP 3.3
- Governor E.C.U
- Feed pump GEAR TYPE
- Injection nozzle Multi hole Type
- Fuel filter Full flow, Cartridge Type
- Used fuel Diesel fuel oil (S<0.05%)

◎ Lubrication System

- Lub. Method Fully forced pressure feed Type
- Oil pump Gear Type driven by crankshaft
- Oil filter Full flow, Cartridge Type
- Oil pan capacity High level 22 liters
Low level 17 liters
- Lub. Oil Refer to Operation Manual

◎ Cooling System

- Cooling method Fresh water forced circulation
- Water capacity 11.5 liters (Engine only)
- Water pump Capacity 350 liters/min at 3,000rpm
- Thermostat Wax – Pellet Type

◎ Electrical System

- Alternator N/A (Vehicle Parts)
- Starting motor 24V x 4.5kW
- Battery Voltage 24V
- Battery Capacity 150AH x 2ea (recommended)

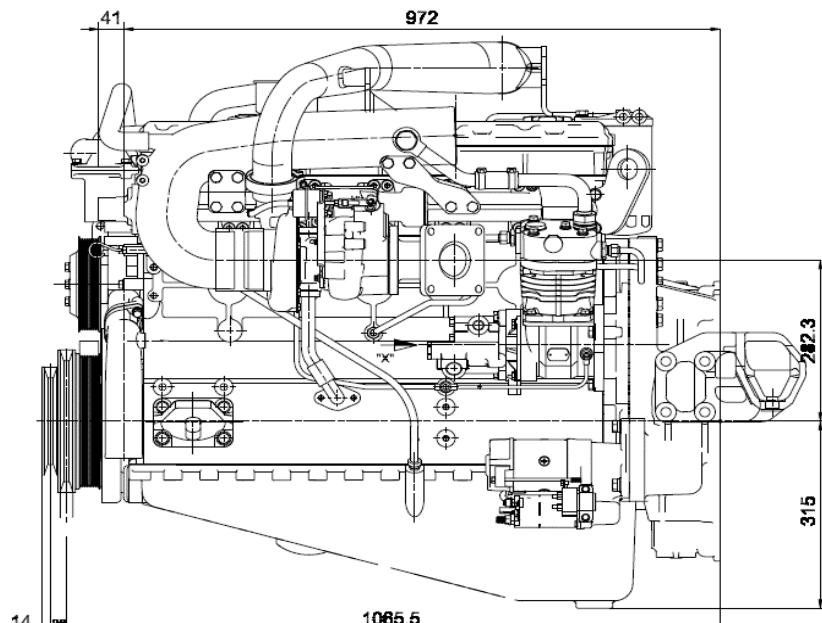
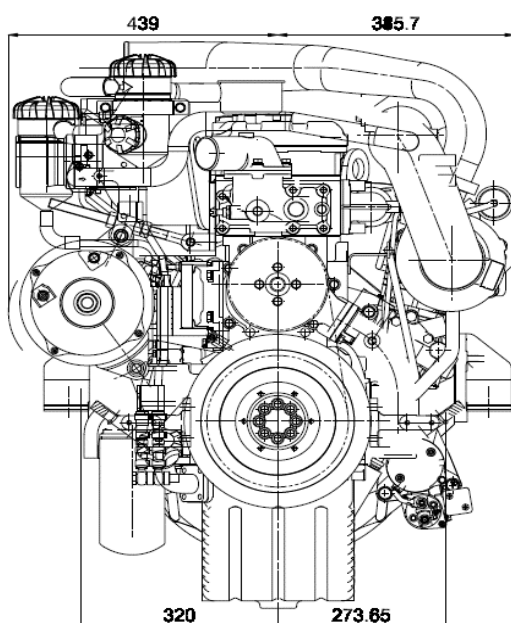

◎ Performance Curve

○ 199kW (270PS) / 100kg.m

○ 184kW (250PS) / 90kg.m

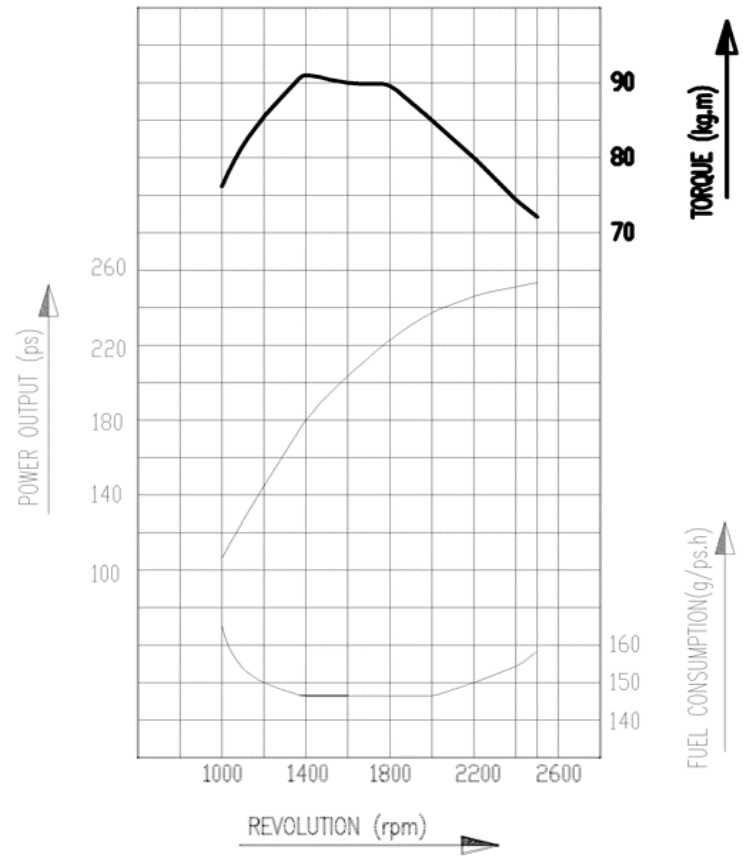
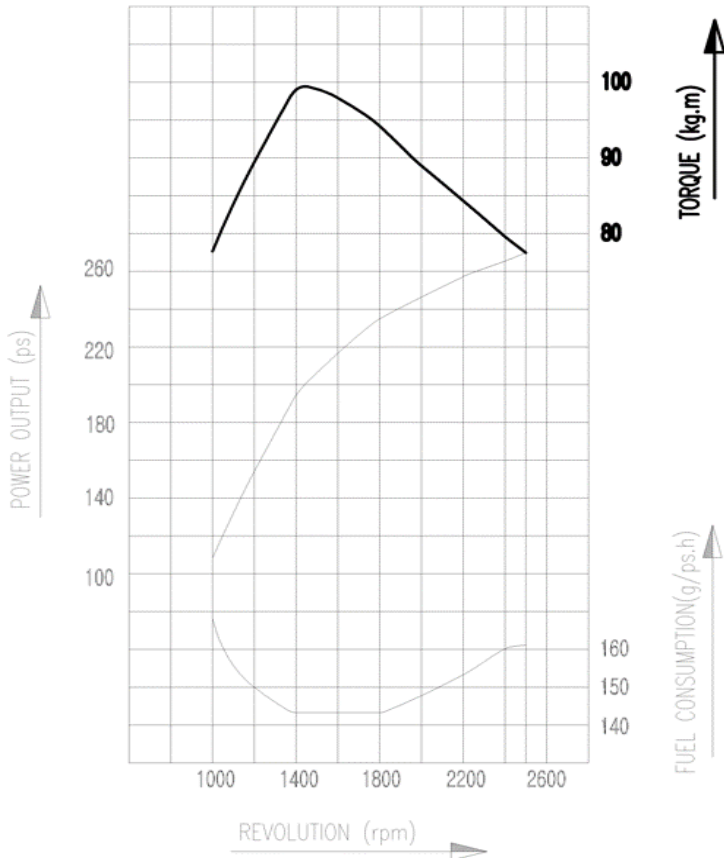

◎ Aftertreatment System

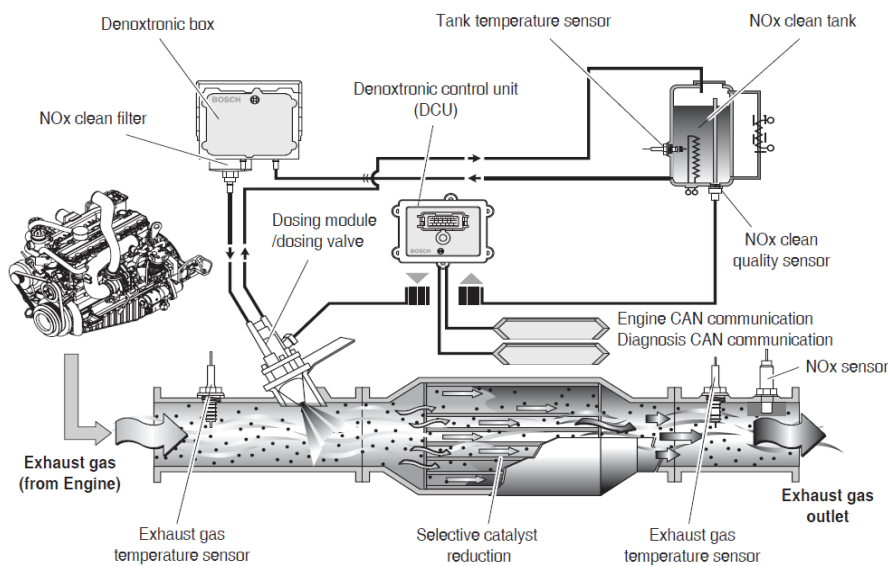

Head office

HD Hyundai Group's Global R&D Center 477,
Bundangsuseo-ro, Seongnam-si Gyeonggi-do,
Korea (13553)

Sales office (Engine)

11F, HD Hyundai Group's Global R&D Center