

POWER RATING

Production tolerance : ± 3%

MODEL	CONDITIONS	POWER	rpm	Base Engine
L126TIH	HEAVY DUTY	360PS (265kW)	2,000	DE12TIB
L126TIM	MEDIUM DUTY	400PS (294kW)	2,100	

Note : 1) No reduction in rating for intake air temperature is up to 45 °C (318K) and sea water temperature is up to 32 °C (305K) , relative humidity is up to 60 % all data are based on operation to ISO 3046.

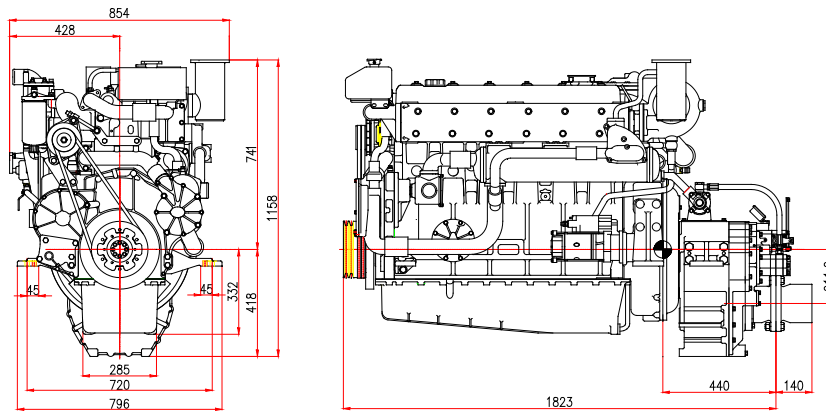

Heavy Duty

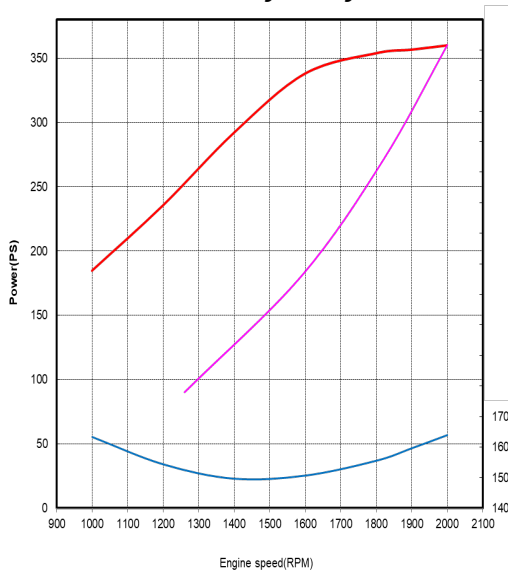

Medium Duty

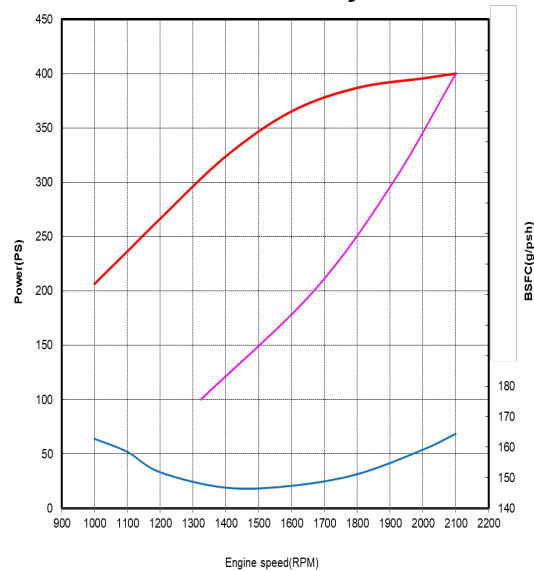

- **Heavy Duty :** Operation hours are unlimited per year, at average load is up to 90 % ,
At full load is up to 80 %
Typical gearbox ratio: 2.5 ~ 6
(Fishing trawler, Tug boat, Pushing vessel, Cargo boat, Freighter, Ferry)
- **Medium Duty :** Operation hours are up to 3,000 per year, at average load is up to 70 %
At full load is (up to 30 % / 4hrs per 12 hour operation period)
Typical gearbox ratio: 2 ~ 3.5
(Fishing boat, Pilot boat, Escort boat, Passenger boat, Ferry, Cruising vessel)

Engine Specification

Model		Units	L126TIH	L126TIM
Engine type			4 cycle, In line, direct-injection, water cooled with wet turbo charger & inter-cooler	
Rating output (B.H.P)		PS(kW)/rpm	360(265)/2,000	400(294)/2,100
Displacement		cc	11,051	
Cylinder number - bore(φ) x stroke		mm	6 - φ123 x 155	
Valve clearance at cold	In / Ex	mm	0.3 / 0.3	
Low idling rpm		rpm	725 ± 25	
No load max. rpm		rpm	below 2,300	below 2,415
Mean effective pressure		kg/cm ²	14.66	15.52
Mean piston speed		m/sec.	10.33	10.85
Compression ratio			17 : 1	
Firing order			1 - 5 - 3 - 6 - 2 - 4	
Compression pressure	at 200 rpm	kg/cm ²	28 (Initial condition)	
Governor type of injection pump			Mechanical variable speed (R.Q.V)	
Fuel consumption		g/PS.h	162	171
		lit / h	69	81
Injection timing (B.T.D.C)		deg	14 ⁰ ±1 ⁰	14 ⁰ ±1 ⁰
Fuel inj. nozzle opening pressure		kg/cm ²	1st : 160 , 2nd : 220	
Starting system			Electric Starting by starter motor	
Starter motor capacity		V- kW	24 - 5.4	
Alternator capacity		V- A	24 - 80	
Battery		V- Ah	24 - 150	
Cooling system			Indirect sea water cooling with heat exchanger	
Cooling water capacity	Max. / Min.	lit	24 / 19	
Fresh water pump type			Centrifugal type, driven by gear	
Sea water pump type			Rubber impeller type driven by gear	
Lubricating oil (Engine)	Pan capacity	lit	Max : 25, Min : 19 (Engine total : 27)	
	Pressure	kg/cm ²	Full : 3.5, Idle : 1.2	
Marine gear	Model		DMT144H (Dong-I)	
	Gear ratio		1.83 2.09 2.51 3.08 3.43	
Direction of revolution	Crankshaft		Counter clockwise viewed from stern side	
	Propeller		Clockwise viewed from stern side	
Engine size (L x W x H)	Without M/G	mm	1,242 x 854 x 1,073	
	With M. gear	mm	1,683 x 854 x 1,159	
Engine dry weight	Without M/G	kg	1,060	
	with M. gear	kg	1,345	

psi = kg/cm² x 14.22
 lb/ft. = N.m x 0.737
 kW = 0.2388 kcal/s

lb = kg x 2.205
 lb/PS.h = g/kW.h x 0.00162
 cfm = m³/min x 35.3

hp = PS x 0.98635
 U.S gal. = liter x 0.264



Head office

HD Hyundai Group's Global R&D Center 477,
 Bundangsuseo-ro, Seongnam-si Gyeonggi-do,
 Korea (13553)

Sales office (Engine)

11F, HD Hyundai Group's Global R&D Center

※ Specifications are subject to change without prior notice.