

HYUNDAI

DP054CBK



GENERATOR



5.0L / 4 CYLINDERS



SWITCHABLE



EPA TIER3

DESCRIPTION

- HD Construction Equipment introduced new generator electronic engines DP054C- Series.
- When compared to other engines of equivalent capacity, it displays a higher output, better fuel efficiency, higher safety, and easier maintenance.
- Achieving precise fuel delivery with common rail system and electronic control unit(ECU), it allows optimal injection timing and pressure based on engine's current operating conditions.



FEATURES & BENEFITS

[High Performance & Durability]

- G3 Class(ISO 8528-5)
- HVO/GTL : Usable up to 100%
- Robust main structure parts
- Oil maintenance interval: 1,000hrs without replenishment
- Operates without power derating up to an altitude of 1,000 meters
- Longer warranty period through strict verification

[Convenience & Safety]

- 50/60 Hz switchable
- Maintenance free through auto tensioning belt drive system
- Cold Startability@-25°C without supplementary device
- Radiator to cover a wide range of usage condition
- Safety guard for hazard parts
- Meet REACH & RoHS regulations

OUTPUT

1,500 RPM (50Hz)									1,800 RPM (60Hz)								
Standby			Prime			Continuous			Standby			Prime			Continuous		
kWm	kWe	kVA	kWm	kWe	kVA	kWm	kWe	kVA	kWm	kWe	kVA	kWm	kWe	kVA	kWm	kWe	kVA
179	162	203	163	147	184	114	101	126	197	175	219	179	158	198	125	108	135

- Generator efficiency (typical) : 93.0%
- kWm= kilo Watt mechanical, Gross power; kWe= kilo Watt electric = (kWm-Fan loss) x Generator eff. kVA= kilo Volt Ampere
- Calculations based on a 0.8 power factor = kWe/0.8
- U.S. EPA TIER 3 Nonroad emission for Stationary Emergency Use Only. Prime/Continuous power rating for reference only.

DP054CBK

GENERAL DATA

Type	Diesel, Water cooled, Turbo charged & Intercooled
Bore	110mm
Stroke	132mm
Displacement liter	5.0 liter
Cylinders and Arrangement	Cast iron, 4 Cylinder, In-line
Battery charging alternator	24V x 45A
Starting voltage	24V
Fuel system	Common rail, Direct injection controlled by ECU
Fuel filter	Full flow, Cartridge type
Lube oil filter type (s)	Full flow, Cartridge type
Lube oil capacity (l)	Max. 26 liters , Min. 15 liters
Flywheel dimensions	SAE NO.3M / Clutch NO.11-1/2"

COOLING SYSTEM

Cooling method	Fresh water forced circulation	
Cooling ratio	50% ethylene glycol; 50% water	
Water capacity (L)	with radiator	33.2 liters
	without radiator	12.5 liters
Fan power (kW)	5.3 kW (1,500 rpm), 9.2 kW (1,800 rpm)	
Cooling system air flow (m ³ /min)	228 m ³ /min (1,500 rpm), 270 m ³ /min (1,800 rpm)	

FUEL CONSUMPTION

1,500 RPM (50Hz)		
%	kWm	Liters/hr
Standby		
100	179.0	44.4
Prime		
100	163.0	41.9
75	122.3	33.4
50	81.5	22.1
25	40.8	12.4
Continuous		
100	114.0	31.2

1,800 RPM (60Hz)		
%	kWm	Liters/hr
Standby		
100	197.0	49.5
Prime		
100	179.0	46.2
75	134.3	37.7
50	89.5	24.9
25	44.8	14.7
Continuous		
100	125.0	36.1

DP054CBK

DIMENSIONS

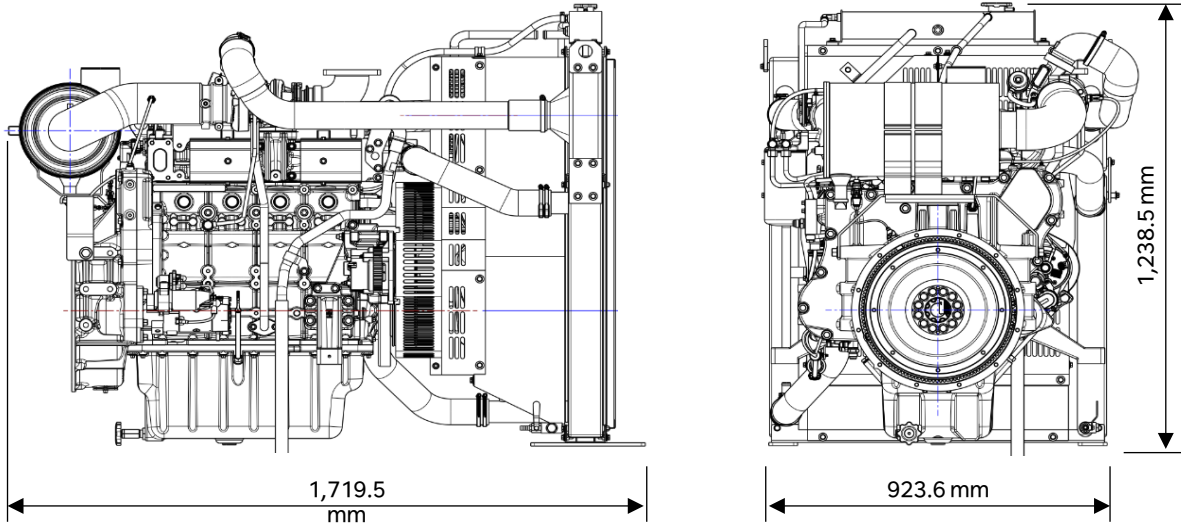

Weights and Dimensions (G-Pack)

Length (mm)	Width (mm)	Height (mm)	Dry Weight (kg)
1,719.5	923.6	1,238.5	718.5

POWER RATING GUIDE

ESP(STANDBY POWER) is applicable for supplying emergency power for the duration of the utility power outage. No overload capability is available for this rating. A standby rated engine should be sized for a maximum of an 70% average load factor and 500 hours of operation per year. This includes less than 25 hours per year at the Standby Power rating.

PRP(PRIME POWER) is available for an unlimited number of hours per year in variable load application. Variable load should not exceed a 70% average of the Prime Power rating during any operating period of 24 hours. The Total operating time at 100% Prime Power shall not exceed 500 hours per year. A 10% overload capability is available for a period of 1 hour within a 12 hours period of operation. Total operating time at the 10% overload power shall not exceed 25 hours per year.

COP(CONTINUOUS POWER) is defined as being the maximum power which the generating set is capable of delivering continuously whilst supplying a constant electrical load when operated for an unlimited number of hours per year under the agreed operating conditions with the maintenance intervals and procedures being carried out as prescribed by the manufacturer.

※ Specifications are subject to change without prior notice.

HD Construction Equipment Co., Ltd.

HD Hyundai Group's Global R&D Center, 477, Bundanguseo-ro, Bundang-gu, Seongnam-si, Gyeonggi-do, Korea (13553)
hd.engineersales@hd.com / www.hd-hyundaiengine.com

HD CONSTRUCTION
EQUIPMENT