



GENERATOR



11.1L / 6 CYLINDERS



EPA TIER3

DESCRIPTION

- HD Construction Equipment introduced new generator electronic engines DP126C- Series.
- When compared to other engines of equivalent capacity, it displays a higher output, better fuel efficiency, higher safety, and easier maintenance.
- Achieving precise fuel delivery with common rail system and electronic control unit(ECU), it allows optimal injection timing and pressure based on engine's current operating conditions.

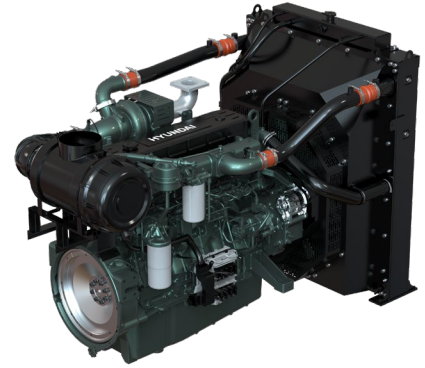

FEATURES & BENEFITS

[High Performance & Durability]

- G3 Class(ISO 8528-5)
- HVO/GTL : Usable up to 100%
- Robust main structure parts
- Oil maintenance interval: 500hrs without replenishment
- Operates without power derating up to an altitude of 1,000 meters
- Longer warranty period through strict verification

[Convenience & Safety]

- Maintenance free through auto tensioning belt drive system
- Radiator to cover a wide range of usage condition
- Safety guard for hazard parts
- Meet REACH & RoHS regulations

OUTPUT

1,500 RPM (50Hz)									1,800 RPM (60Hz)								
Standby			Prime			Continuous			Standby			Prime			Continuous		
kWm	kWe	kVA	kWm	kWe	kVA	kWm	kWe	kVA	kWm	kWe	kVA	kWm	kWe	kVA	kWm	kWe	kVA
-	-	-	-	-	-	-	-	-	375	331	414	341	299	374	239	203	254

- Generator efficiency (typical) : 94.0%
- kWm= kilo Watt mechanical, Gross power; kWe= kilo Watt electric = (kWm-Fan loss) x Generator eff.
kVA= kilo Volt Ampere
- Calculations based on a 0.8 power factor = kWe/0.8
- U.S. EPA TIER 3 Nonroad emission for Stationary Emergency Use Only.
Prime/Continuous power rating for reference only.

DP126CAK

GENERAL DATA

Type	Diesel, Water cooled, Turbo charged & Intercooled
Bore	123mm
Stroke	155mm
Displacement liter	11.1 liter
Cylinders and Arrangement	Cast iron, 6 Cylinder, In-line type
Battery charging alternator	24V x 80A
Starting voltage	24V
Fuel system	Common rail, Direct injection controlled by ECU
Fuel filter	Full flow, Cartridge type
Lube oil filter type (s)	Full flow, Cartridge type
Lube oil capacity (l)	Max. 44 liters , Min. 20 liters
Flywheel dimensions	SAE NO.1M / Clutch NO.14"

COOLING SYSTEM

Cooling method	Fresh water forced circulation	
Cooling ratio	50% ethylene glycol / 50% water	
Water capacity (L)	with radiator	53 liters
	without radiator	23 liters
Fan power (kW)	- kW (1,500 rpm), 23 kW (1,800 rpm)	
Cooling system air flow (m ³ /min)	- m ³ /min (1,500 rpm), 483 m ³ /min (1,800 rpm)	

FUEL CONSUMPTION

1,500 RPM (50Hz)		
%	kWm	Liters/hr
Standby		
100	-	-
Prime		
100	-	-
75	-	-
50	-	-
25	-	-
Continuous		
100	-	-

1,800 RPM (60Hz)		
%	kWm	Liters/hr
Standby		
100	375.0	96.0
Prime		
100	341.0	-
75	255.8	-
50	170.5	-
25	85.3	-
Continuous		
100	239.0	-

DP126CAK

DIMENSIONS

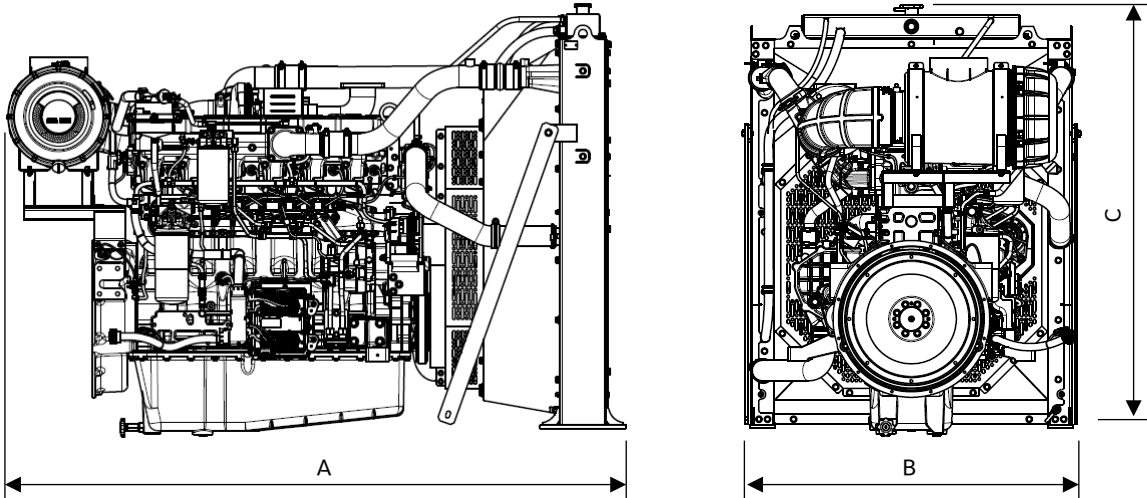

Weights and Dimensions (G-Pack)

Radiator Type	Length – A	Width – B	Height – C	Dry Weight
Ex-Tropical	2,171 mm	1,170 mm	1,491 mm	1,234 kg

POWER RATING GUIDE

The power ratings of Emergency Standby and Prime are in accordance with ISO 8528. Fuel Stop power in accordance with ISO 3046. Electric power (kWe) must be considered cooling fan loss, alternator efficiency, altitude derating and ambient temperature.

ESP (STANDBY POWER) is applicable for supplying emergency power for the duration of the utility power outage. No overload capability is available for this rating. A standby rated engine should be sized for a maximum of an 70% average load factor and 500 hours of operation per year. This includes less than 25 hours per year at the Standby Power rating.

※ Specifications are subject to change without prior notice.

HD Construction Equipment Co., Ltd.

HD Hyundai Group's Global R&D Center, 477, Bundanguseo-ro, Bundang-gu, Seongnam-si, Gyeonggi-do, Korea (13553)
hd.engineersales@hd.com / www.hd-hyundaiengine.com

HD CONSTRUCTION
EQUIPMENT