

# HYUNDAI

# 4AD126C



MARINE

## Power Rating

Conditions	Model	Max. Power		rpm	Emission
		kW	PS		
50Hz	4AD126CA(F)	287	390	1500	IMO Tier II/III EPA Tier 3
60Hz	4AD126CA(S)	335	455	1800	
	4AD126CB(S)	280	381	1800	

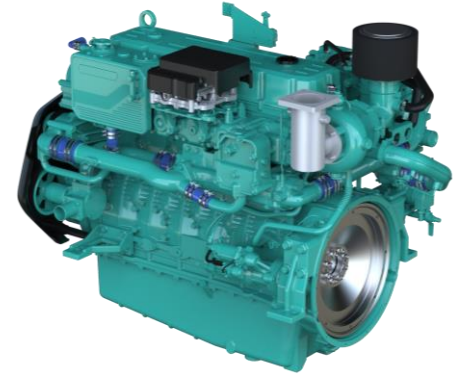

\* No reduction in rating for intake air temperature is up to 45°C (318K) and sea water temperature is up to 32°C (305K), relative humidity is up to 60%

\* All data are based on operation to ISO 3046. Performance tolerance of ±3%

## Key Features and Benefit

### High Performance

- Advanced fuel injection system with common rail
- Compliance with emission regulation (IMO Tier II/III, EPA Tier 3)
- High-efficiency SCR
- Smoke reduction
- Increased durability of key components

### Convenience

- Auto tensioner
- Turning device
- Electrical oil drain pump
- CCV for engine room cleanliness

### Economical

- Decreasing fuel consumption to average 5% by downsizing
- Increased oil & filter replacement cycle (250hr → 500hr)

### Warranty

- Maximum 3 years warranty provided through extended warranty option

### Engine Specifications

Engine Model	4AD126C (DX12)	
Cylinders and Arrangement	6-cylinder / L type	
Bore x Stroke	123 x 155 mm	
Displacement	11.1 liter	
Compression Ratio	15.5 : 1	
Firing Order	1-5-3-6-2-4	
Direction of Revolution	Counterclockwise viewed from Flywheel	
Fuel system	Common rail controlled by ECU	
Starting system	Electric starting by starter motor	
Starter motor capacity	24V - 7.0A	
Alternator capacity	24V - 80Ah	
Battery	24V - 200Ah	
Aspiration	Water cooled with turbo charger & Inter-cooler	
Flywheel Housing	SAE #1 (FW: 14")	
Cooling system	Indirect sea water cooling with heat exchanger / Keel Cooling	
Cooling water capacity	Max: 42 liter, Min : 39 liter	
Fresh water pump type	Centrifugal (Pulley type)	
Sea water pump type	Rubber Impeller	
After Treatment System	IMO Tier-II / EPA Tier 3: Not Required IMO Tier-III : SCR	
Lubricant	Oil pan capacity	Max : 44 liter, Min : 20 liter
	Oil Pressure	Full load : 3.0, Idle : 1.0 (kg /cm <sup>2</sup> )
Dimension (L x W x H)	1608 x 913 x 1288 mm	
Dry Weight	1182 kg	

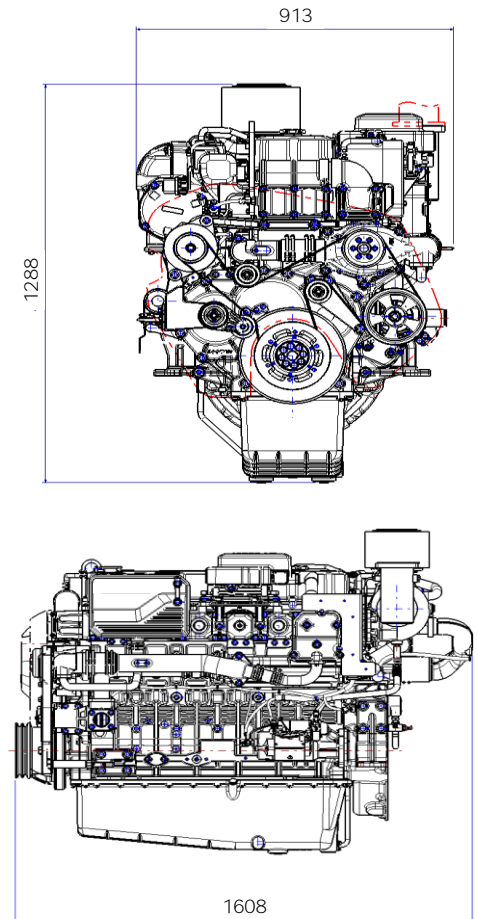

※ Specifications are subject to change without prior notice.

