

HYUNDAI

4AD066C



MARINE

Power Rating

Conditions	Model	Max. Power		rpm	Emission
		kW	PS		
50Hz	4AD066CA(F)	154	209	1500	IMO Tier II/III EPA Tier 3
	4AD066CB(F)	129	175	1500	
	4AD066CC(F)	100	136	1500	
	4AD066CD(F)	180	109	1500	
60Hz	4AD066CA(S)	184	250	1800	
	4AD066CB(S)	140	190	1800	
	4AD066CC(S)	120	163	1800	
	4AD066CD(S)	100	136	1800	

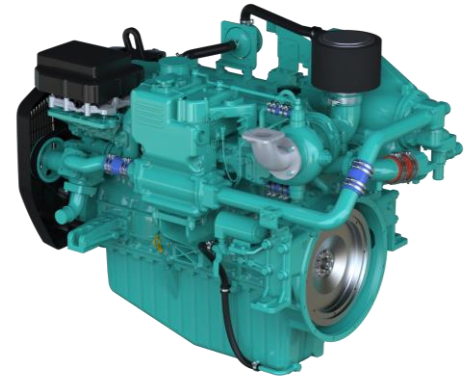

* No reduction in rating for intake air temperature is up to 45°C (318K) and sea water temperature is up to 32°C (305K), relative humidity is up to 60%

* All data are based on operation to ISO 3046. Performance tolerance of ±3%

Key Features and Benefit

High Performance

- Advanced fuel injection system with common rail
- Compliance with emission regulation (IMO Tier II/III, EPA Tier 3)
- High-efficiency SCR
- Smoke reduction
- Increased durability of key components

Convenience

- Auto tensioner
- Turning device
- Electrical oil drain pump
- CCV for engine room cleanliness

Economical

- Decreasing fuel consumption to average 5% by downsizing
- Increased oil & filter replacement cycle (250hr → 500hr)

Warranty

- Maximum 3 years warranty provided through extended warranty option

Engine Specifications

Engine Model	4AD066C (DL06)	
Cylinders and Arrangement	6-cylinder / L type	
Bore x Stroke	100 x 125 mm	
Displacement	5.9 liter	
Compression Ratio	17.0 : 1	
Firing Order	1-5-3-6-2-4	
Direction of Revolution	Counterclockwise viewed from Flywheel	
Fuel system	Common rail controlled by ECU	
Starting system	Electric starting by starter motor	
Starter motor capacity	24V - 6.0A	
Alternator capacity	24V - 80Ah	
Battery	24V - 200Ah	
Aspiration	Water cooled with turbo charger & Inter-cooler	
Flywheel Housing	SAE #2 (FW: 11.5")	
Cooling system	Indirect sea water cooling with heat exchanger / Keel Cooling	
Cooling water capacity	26 liter	
Fresh water pump type	Centrifugal (Pulley type)	
Sea water pump type	Rubber Impeller	
After Treatment System	IMO Tier-II / EPA Tier 3: Not Required IMO Tier-III : SCR	
Lubricant Oil	Oil pan capacity	Max : 32 liter, Min : 14 liter
	Pressure	Full load : 3.0, Idle : 1.0 (kg /cm ²)
Dimension (L x W x H)	1408 x 837 x 1155 mm	
Dry Weight	753 kg	

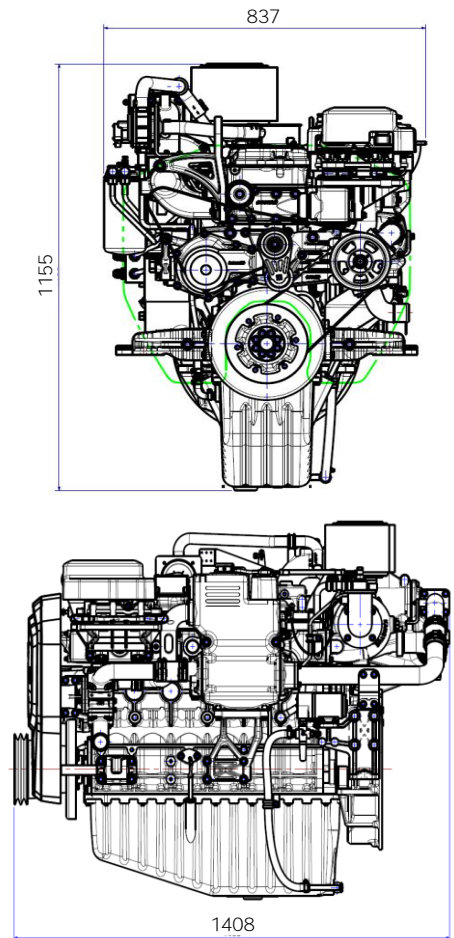

※ Specifications are subject to change without prior notice.

