

POWER RATING

Production tolerance : ± 3%

MODEL	CONDITIONS	POWER	rpm	Base Engine
V222TIH	HEAVY DUTY	720PS (530kW)	1,800	D2842LB
V222TIM	MEDIUM DUTY	800PS (588kW)	2,100	
V222TIL	LIGHT DUTY	1000PS (736kW)	2,300	

Note : 1) No reduction in rating for intake air temperature is up to 45 °C (318K) and sea water temperature is up to 32 °C (305K) , relative humidity is up to 60 % all data are based on operation to ISO 3046.

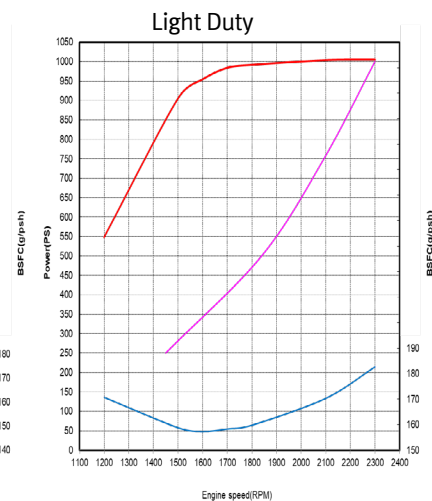
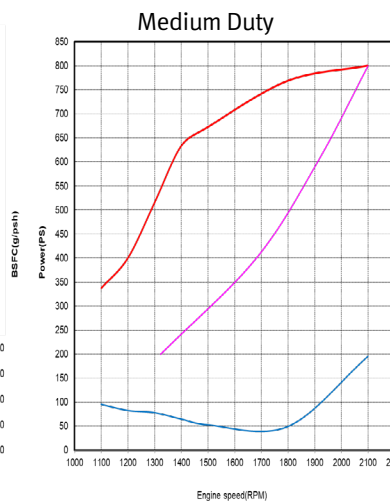
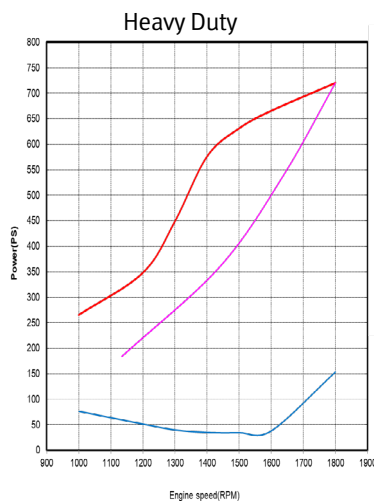
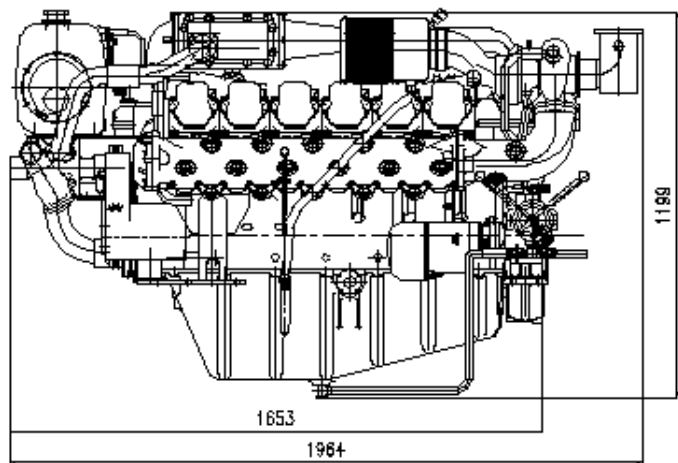
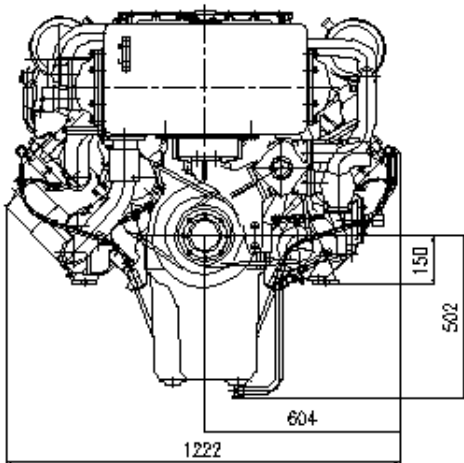

- **Heavy Duty** : Operation hours are unlimited per year, at average load is up to 90 % , at full load is up to 80 %
Typical gearbox ratio: 2.5 ~ 6
(Fishing trawler, Tug boat, Pushing vessel, Cargo boat, Freighter, Ferry)
- **Medium Duty** : Operation hours are up to 3,000 per year, at average load is up to 70 %
At full load is (up to 30 % / 4hrs per 12 hour operation period)
Typical gearbox ratio: 2 ~ 3.5
(Fishing boat, Pilot boat, Escort boat, Passenger boat, Ferry, Cruising vessel)
- **Light Duty** : Operation hours are up to 1,000 per year, at average load is up to 50 %
At full load is (up to 20 % / 2hrs per 12 hour operation period)
Typical gearbox ratio: 1 ~ 2.5
(Light weight fishing boat, Yacht, Coastguard boat, Fast boat, Fire pump, Navy)

Engine Specification

Model		Units	V222TIH	V222TIM	V222TIL
Engine type			4 cycle, V type, direct- injection, water cooled with wet turbo charger & inter-cooler		
Rating output (B.H.P)		PS(kW)/rpm	720(530)/1,800	800(588)/2,100	1000(736)/2,300
Displacement		cc	21,927		
Cylinder number - bore(φ) x stroke		mm	12 - φ128 x 142		
Valve clearance at cold	In / Ex	mm	0.25 / 0.35		
Low idling rpm		rpm	725 ± 25		
No load max. rpm		rpm	below 2,070	below 2,415	below 2,645
Mean effective pressure		kg/cm ²	16.4	15.6	17.9
Mean piston speed		m/sec.	8.52	9.94	10.89
Compression ratio			15.5 : 1	15.5 : 1	15.5 : 1
Firing order			1 - 12 - 5 - 8 - 3 - 10 - 6 - 7 - 2 - 11 - 4 - 9		
Governor type of injection pump			Mechanical variable speed (R.Q.V)		
Fuel consumption		g / PS.h	171	179	183
		Lit / h	148	173	221
Injection timing (B.T.D.C)		deg	20 °± 1°	20 °± 1°	20 °± 1°
Starting system			Electric Starting by starter motor		
Starter motor capacity		V - kW	24 - 6.6		
Alternator capacity		V - A	24 - 80		
Battery		V - Ah	24 - 200		
Cooling system			Indirect sea water cooling with heat exchanger		
Cooling water capacity	Max. / Min.	lit.	98 / 87		
Fresh water pump type			Centrifugal type, driven by belt		
Sea water pump type			Rubber impeller type driven by belt		
Lubricating oil (Engine)	pan capacity	lit.	Max : 40, Min : 33 (Engine total : 43)		
	pressure	kg/cm ²	Full : 3.5, Idle : 1.2		
Direction of revolution	crankshaft		Counter clockwise viewed from stern side		
Engine Size (L x W x H)		mm	1,653 x 1,222 x 1,199		
Engine dry weight		kg	1,750	1,750	1,830

psi = kg/cm² x 14.22
 lb/ft. = N.m x 0.737
 kW = 0.2388 kcal/s

lb = kg x 2.205
 lb/PS.h = g/kW.h x 0.00162
 cfm = m³/min x 35.3

hp = PS x 0.98635
 U.S gal. = liter x 0.264



Head office

HD Hyundai Group's Global R&D Center 477,
 Bundanguseo-ro, Seongnam-si Gyeonggi-do,
 Korea (13553)

Sales office (Engine)

11F, HD Hyundai Group's Global R&D Center

※ Specifications are subject to change without prior notice.