

**POWER RATING**

Production tolerance : ± 3%

MODEL	CONDITIONS	POWER	rpm	Base Engine
4V158TIH	HEAVY DUTY	390kW (530PS)	1,800	D2848LB
4V158TIM	MEDIUM DUTY	441kW (600PS)	2,100	
4V158TIL	LIGHT DUTY	588kW (800PS)	2,300	

**Note : 1)** No reduction in rating for intake air temperature is up to 45 °C (318K) and sea water temperature is up to 32 °C (305K) , relative humidity is up to 60 % all data are based on operation to ISO 3046.

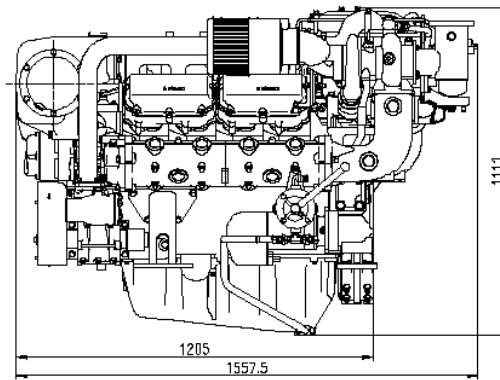
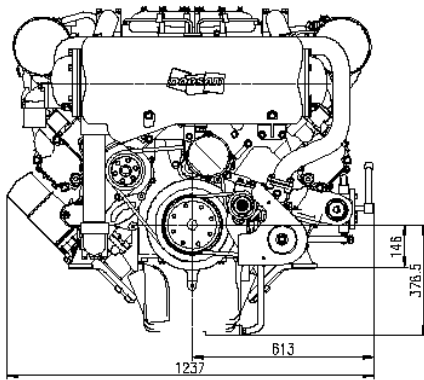

Heavy Duty

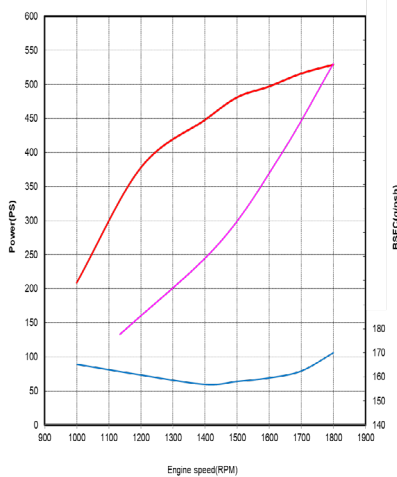

Medium Duty

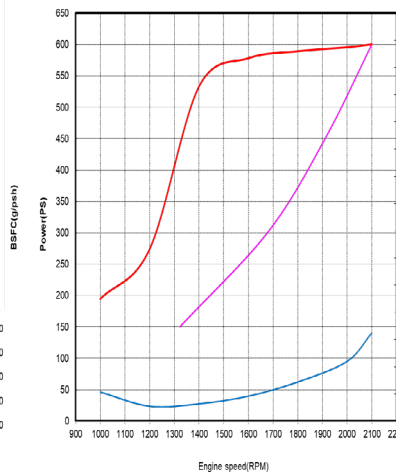

Light Duty

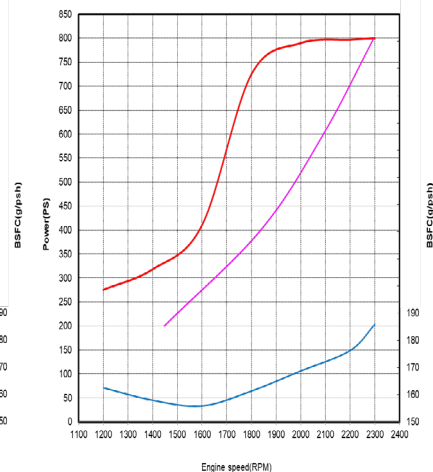

- **Heavy Duty** : Operation hours are unlimited per year, at average load is up to 90 % , at full load is up to 80 %  
 Typical gearbox ratio: 2.5 ~ 6  
 (Fishing trawler, Tug boat, Pushing vessel, Cargo boat, Freighter, Ferry)
- **Medium Duty** : Operation hours are up to 3,000 per year, at average load is up to 70 %  
 At full load is (up to 30 % / 4hrs per 12 hour operation period).  
 Typical gearbox ratio: 2 ~ 3.5  
 (Fishing boat, Pilot boat, Escort boat, Passenger boat, Ferry, Cruising vessel)
- **Light Duty** : Operation hours are up to 1,000 per year, at average load is up to 50 %  
 At full load is (up to 20 % / 2hrs per 12 hour operation period)  
 Typical gearbox ratio: 1 ~ 2.5  
 (Light weight fishing boat, Yacht, Coastguard boat, Fast boat, Fire pump, Navy, Bow thruster)

Engine Specification					
Model		Units	4V158TIH	4V158TIM	4V158TIL
Engine type			4 valve, 4 cycle, V type, direct- injection, water cooled with wet turbo charger & inter-cooler		
Rating output (B.H.P)		kW(PS)/rpm	390(530)/1,800	441(600)/2,100	588(800)/2,300
Displacement		cc	14,618		
Cylinder number - bore(φ) x stroke		mm	8 - φ128 x 142		
Valve clearance at cold	In / Ex	mm	0.40 / 0.50		
Low idling rpm		rpm	725 ± 25		
No load max. rpm		rpm	below 2,070	below 2,415	below 2,645
Mean effective pressure		kg/cm <sup>2</sup>	18.1	17.6	21.4
Mean piston speed		m/sec.	8.52	9.94	10.89
Compression ratio			15.8 : 1	15.8 : 1	15.8 : 1
Firing order			1 - 5 - 7 - 2 - 6 - 3 - 4 - 8		
Governor type of injection pump			Mechanical variable speed (R.Q.V)		
Fuel consumption		g / PS.h	170	182	186
		Lit / h	108	132	179
Starting system			Electric Starting by starter motor		
Starter motor capacity		V - kW	24 - 6.6		
Alternator capacity		V - A	24 - 80		
Battery		V - Ah	24 - 200		
Cooling system			Indirect sea water cooling with heat exchanger		
Cooling water capacity	Max. / Min.	lit.	94 / 83		
Fresh water pump type			Centrifugal type, driven by belt		
Sea water pump type			Rubber impeller type driven by belt		
Lubricating oil (Engine)	pan capacity	lit.	Max : 31, Min : 25 (Engine total : 35)		
	pressure	kg/cm <sup>2</sup>	Full : 3.5, Idle : 1.2		
Direction of revolution	crankshaft		Counter clockwise viewed from stern side		
Engine Size ( L x W x H )		mm	1,205 x 1,237 x 1,111		
Engine dry weight		kg	1,540	1,540	1,580

psi = kg/cm<sup>2</sup> x 14.22  
 lb/ft. = N.m x 0.737  
 kW = 0.2388 kcal/s

lb = kg x 2.205  
 lb/PS.h = g/kW.h x 0.00162  
 cfm = m<sup>3</sup>/min x 35.3

hp = PS x 0.98635  
 U.S gal. = liter x 0.264



### Head office

HD Hyundai Group's Global R&D Center 477,  
 Bundangsuseo-ro, Seongnam-si Gyeonggi-do,  
 Korea (13553)

### Sales office (Engine)

11F, HD Hyundai Group's Global R&D Center

※ Specifications are subject to change without prior notice.