

POWER RATING		Production tolerance : ± 3%		
MODEL	CONDITIONS	POWER	rpm	Base Engine
L136T	HEAVY DUTY	200PS (147kW)	2200	D1146T
L136TL	LIGHT DUTY	240PS(177Kw)	2500	

Note : 1) No reduction in rating for intake air temperature is up to 45 °C (318K) and sea water temperature is up to 32 °C (305K) , relative humidity is up to 60 % all data are based on operation to ISO 3046.

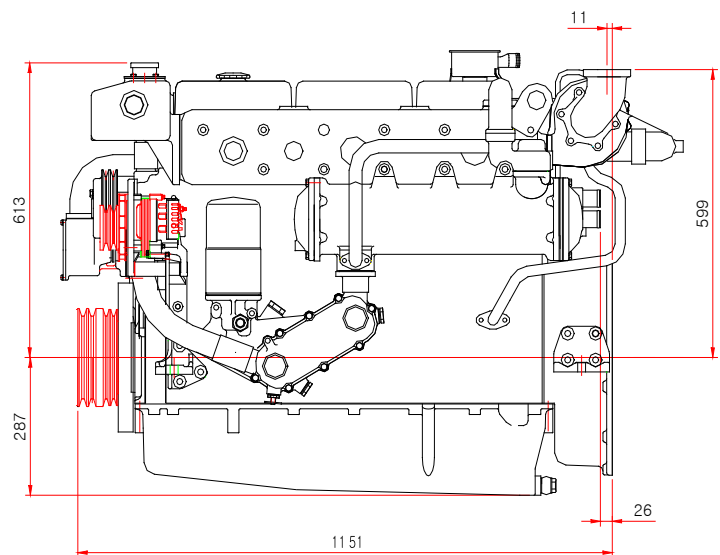

Heavy Duty

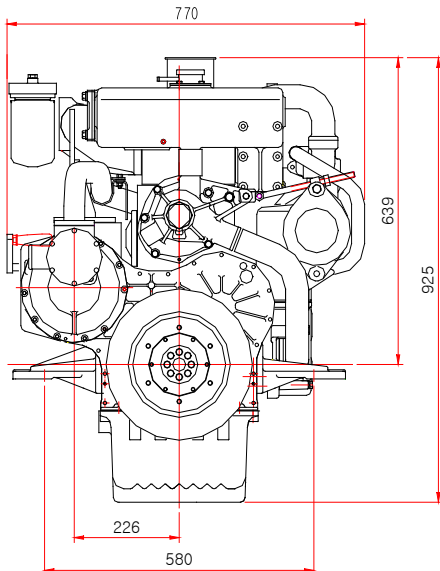
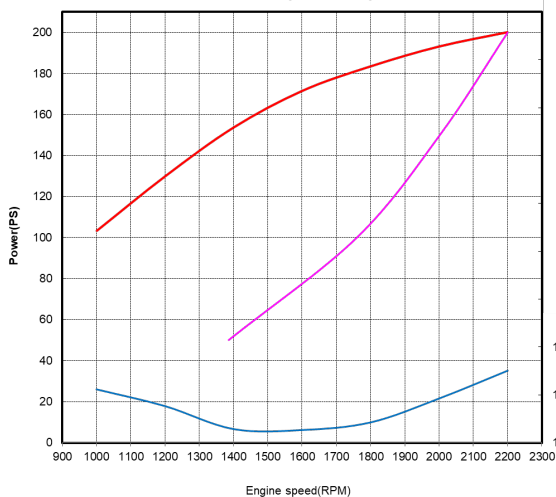

Light Duty

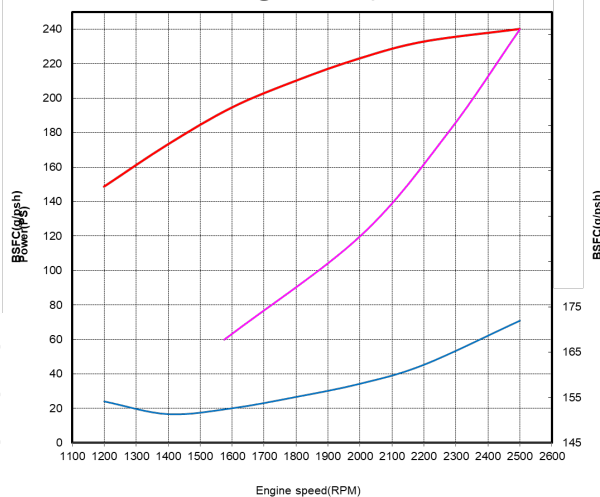

- **Heavy Duty** : Operation hours are unlimited per year, at average load is up to 90 % ,
At full load is up to 80 %
Typical gearbox ratio: 2.5 ~ 6
(Fishing trawler, Tug boat, Pushing vessel, Cargo boat, Freighter, Ferry)
- **Light Duty** : Operation hours are up to 1,000 per year, at average load is up to 50 %
At full load is (up to 20 % / 2hrs per 12 hour operation period)
Typical gearbox ratio: 1 ~ 2.5
(Light weight fishing boat, Yacht, Coastguard boat, Fast boat, Fire pump)

Engine Specification				
Model		Units	L136T	L136TL
Engine type			4 cycle, In line, direct- injection, water cooled with turbo charger	
Rating output (B.H.P)		PS(kW)/rpm	200(147)/2200	240(177)/2500
Displacement		cc	8,071	
Cylinder number - bore(φ) x stroke		mm	6 - φ111 x 139	
Valve clearance at cold	In / Ex	mm	0.3 / 0.3	
Low idling rpm		rpm	725 ± 25	
No load max. rpm		rpm	below 2,400	below 2,750
Mean effective pressure		kg/cm ²	10.14	10.71
Mean piston speed		m/sec.	10.19	11.58
Compression ratio			16.7 : 1	
Firing order			1 - 5 - 3 - 6 - 2 - 4	
Compression pressure	at 200 rpm	kg/cm ²	28 (Initial Condition)	
Governor type of injection pump			Mechanical all speed (R.S.V)	
Fuel consumption		g/ps.h	165	172
		lit / h	39.5	49.4
Injection timing (B.T.D.C)		deg	18° ± 1°	
Fuel inj. nozzle opening pressure		kg/cm ²	214+8	
Starting system			Electric Starting by starter motor	
Starter motor capacity		V- kW	24 - 4.5	
Alternator capacity		V- A	24 - 80	
Battery		V- Ah	24 - 100	
Cooling system			Indirect sea water cooling with heat exchanger	
Cooling water capacity	Max. / Min.	lit	27 / 25	
Fresh water pump type			Centrifugal type, driven by V- belt	
Sea water pump type			Rubber impeller type driven by gear	
Lubricating Oil (Engine)	pan capacity	lit	Max : 23 , Min : 17 (Engine total : 25)	
	pressure	kg/cm ²	Full : 3.5, Idle : 1.2	
Marine Gear	Model		DMT90A (Dong-I)	
	Gear ratio		1.61 2.06 2.45 2.82 3.12 3.46	
Direction of revolution	crankshaft		Counter clockwise viewed from stern side	
	propeller		Clockwise viewed from stern side	
Engine size (L x W x H)	without M/G	mm	1,182 x 770 x 925	
	with M. gear	mm	1,542 x 770 x 963	
Engine dry weight	without M/G	kg	748	
	with M. gear	kg	938	

psi = kg/cm² x 14.22
 lb/ft. = N.m x 0.737
 kW = 0.2388 kcal/s

lb= kg x 2.205
 lb/PS.h = g/kW.h x 0.00162
 cfm = m³/min x 35.3

hp = PS x 0.98635
 U.S gal. = liter x 0.264



Head office

HD Hyundai Group's Global R&D Center 477,
 Bundangsuseo-ro, Seongnam-si Gyeonggi-do,
 Korea (13553)

Sales office (Engine)

11F, HD Hyundai Group's Global R&D Center

※ Specifications are subject to change without prior notice.