

◎ Production Tolerance : ±5%

Intermittent rating kW(HP) / rpm	Max. torque N.m(kg.m) / rpm	Aftertreatment
250 (340) / 2200	1423 (145) / 1200	SCR
221 (300) / 2200	1128 (115) / 1200	

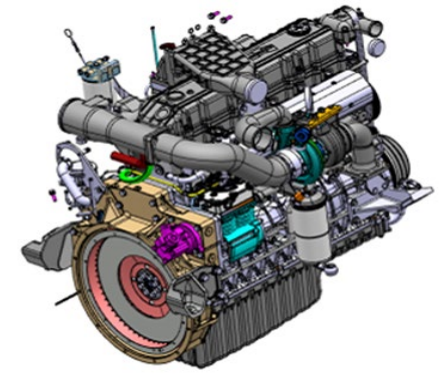

◎ General Specification

- Engine Model DL08K
- Engine Type In-Line, 4 Cycle, Water Cooled
Thrbographed & Intercooled
- Injection System Electronic Common Rail
- Cylinder Type Replaceable dry liner
- Number of Cylinders 6
- Bore x stroke 108 x 139 mm
- Displacement 7.6 L
- Compression ratio 16.5 : 1
- Firing order 1-5-3-6-2-4
- Dry weight 836 kg (Engine only)
- Dimension 1214 x 801 x 1085 mm
- Rotation CCW viewed from Flywheel
- Breather System CCV / Mesh + Filter (Dual)
- No Load Max Engine Speed 2,420 +10/-50rpm
- No Load Min Engine Speed 600 +/- 10rpm
- Flywheel Housing SAE1
- Flywheel Size 17 inch Push
- Turbocharger Waste Gate Valve
- Air Compressor Capacity 440cc/rev (Single)

◎ Valve System

- Type Over Head Valve
- Number of Valve Intake 2, Exhaust 2 per Cylinder
- Valve Lashes at Cold Intake 0.3 mm
Exhaust 0.4 mm

◎ Fuel System

- Injection pump BOSCH CP3.3
- Governor E.C.U
- Feed pump GEAR TYPE
- Injection nozzle Multi hole Type
- Fuel filter Full flow, Catridge Type
- Used fuel Diesel fuel oil

◎ Lubrication System

- Lub. Method Fully forced pressure feed Type
- Oil pump Gear Type driven by crankshaft
- Oil filter Full flow, Catridge Type
- Oil pan capacity High level 27 liters
Low level 21 liters
- Lub. Oil API CJ-4 Grade, 10W30 or 10W40

◎ Cooling System

- Cooling method Fresh water forced circulation
- Water capacity 17.7 liters (Engine only)
- Water pump Capacity 400 liters/min at 3,055rpm
- Thermostat Wax – Pellet Type

◎ Electrical System

- Alternator N/A (Vehicle Parts)
- Starting motor 24V x 6.0kW
- Battery Voltage 24V
- Battery Capacity 150AH x 2ea (recommended)

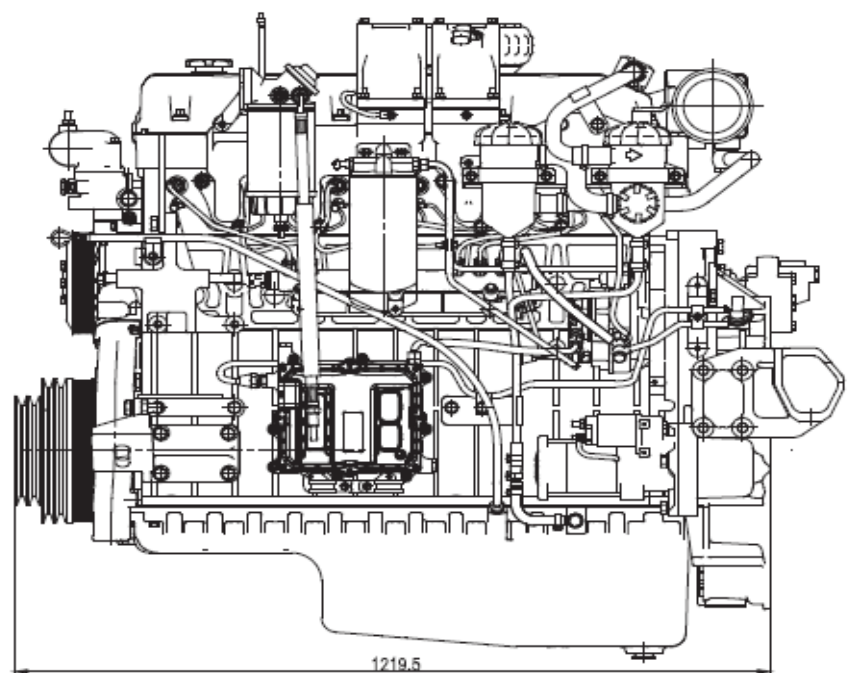
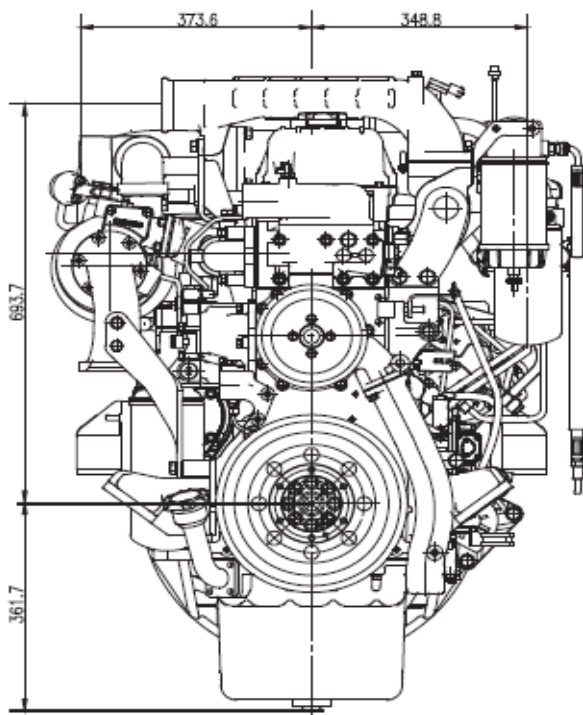

⊙ **Performance Curve**

○ 250kW (340PS) / 145kg.m

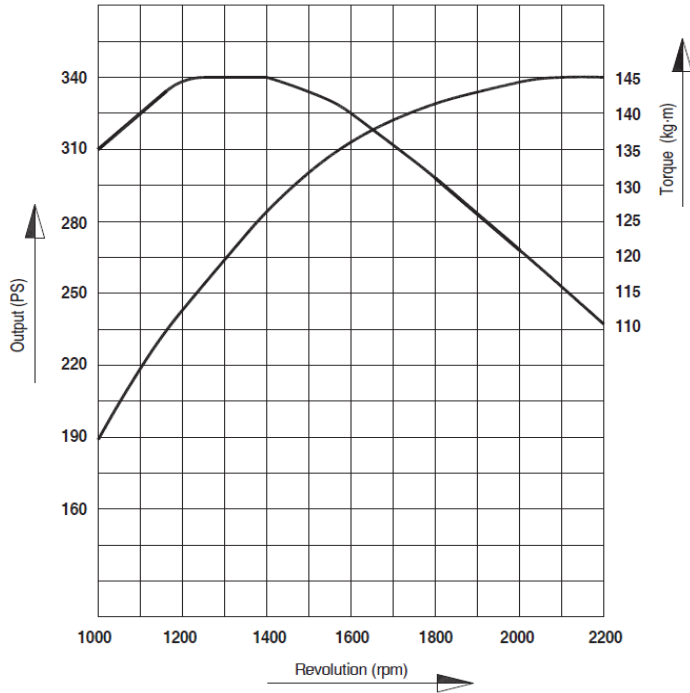

○ 221kW (300PS) / 115kg.m

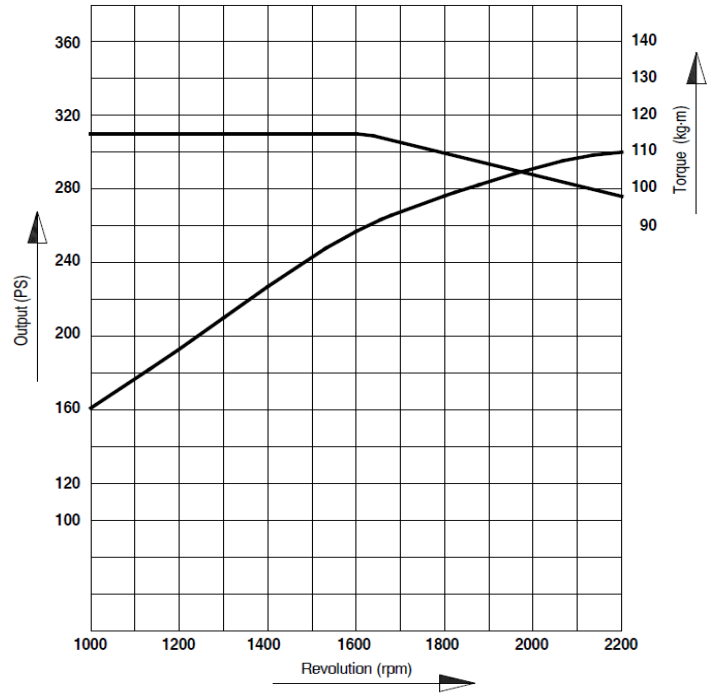

⊙ **Aftertreatment System**

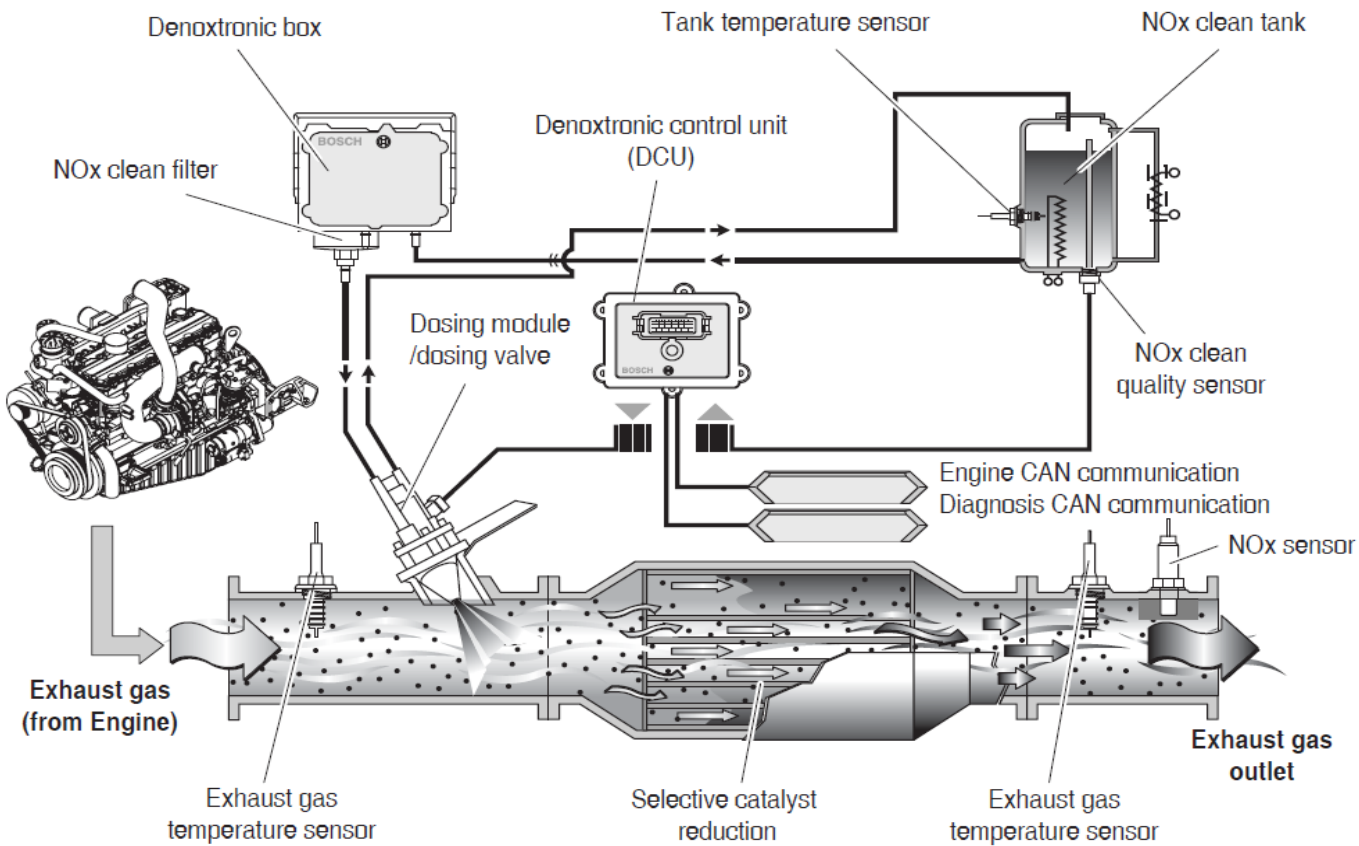

Head office
 HD Hyundai Group's Global R&D Center 477,
 Bundangseuseo-ro, Seongnam-si Gyeonggi-do,
 Korea (13553)

Sales office (Engine)
 11F, HD Hyundai Group's Global R&D Center

※ Specifications are subject to change without prior notice