

◎ Production Tolerance : ±5%

Intermittent rating kW(HP) / rpm	Max. torque N.m(kg.m) / rpm	Aftertreatment
338 (460) / 1900	2206 (225) / 1200	DOC+DPF+SCR
324 (440) / 1900	1991 (203) / 1200	

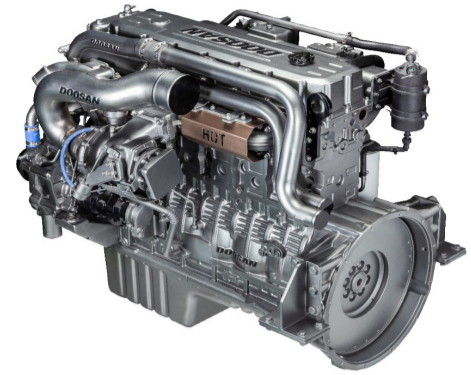

◎ General Specification

○ Engine Model	DX12P
○ Engine Type	In-line, 4 Cycle, Water Cooled Turbocharged & Intercooled
○ Injection System	Electronic Common Rail
○ Cylinder Type	Replaceable dry liner
○ Number of Cylinders	6
○ Bore x stroke	123 x 155 mm
○ Displacement	11.1L
○ Compression ratio	17.1 : 1
○ Firing order	1-5-3-6-2-4
○ Dry weight	1,000 kg (Engine only)
○ Dimension	1,326 x 1,071 x 1,123 mm
○ Rotation	CCW viewed from Flywheel
○ Breather System	CCV
○ No Load Max Engine Speed	2,100 +/- 50rpm
○ No Load Min Engine Speed	600 +/- 50rpm
○ Flywheel Housing	SAE1 / Pull Type
○ Air Compressor Capacity	354cc/rev (Single) 636cc/rev (Twin)

◎ Valve System

○ Type	Over Head Valve
○ Number of Valve	Intake 2, Exhaust 2 per Cylinder
○ Valve Lashes at Cold	Intake 0.4mm Exhaust 0.5mm

◎ Fuel System

○ Injection pump	BOSCH CP 3.4
○ Feed pump	GEAR TYPE
○ Injection nozzle	DLA Maxi Type
○ Fuel filter	Full flow, Cartridge Type
○ Used fuel	Diesel fuel oil

◎ Lubrication System

○ Lub. Method	Fully forced pressure feed Type
○ Oil pump	Gear Type driven by crankshaft
○ Oil filter	Full flow, Cartridge Type
○ Oil pan capacity	High level 26 liters Low level 16 liters
○ Lub. Oil	API CJ-4 Grade 10W40

◎ Cooling System

○ Cooling method	Fresh water forced circulation
○ Water capacity	23.0 liters (Engine only)
○ Water pump Capacity	500 liters/min at 1,900rpm
○ Thermostat	Wax - Pellet Type

◎ Electrical System

○ Alternator	N/A (Vehicle Parts)
○ Starting motor	24V x 6.0kW
○ Battery Voltage	24V
○ Battery Capacity	150AH x 2ea (recommended)

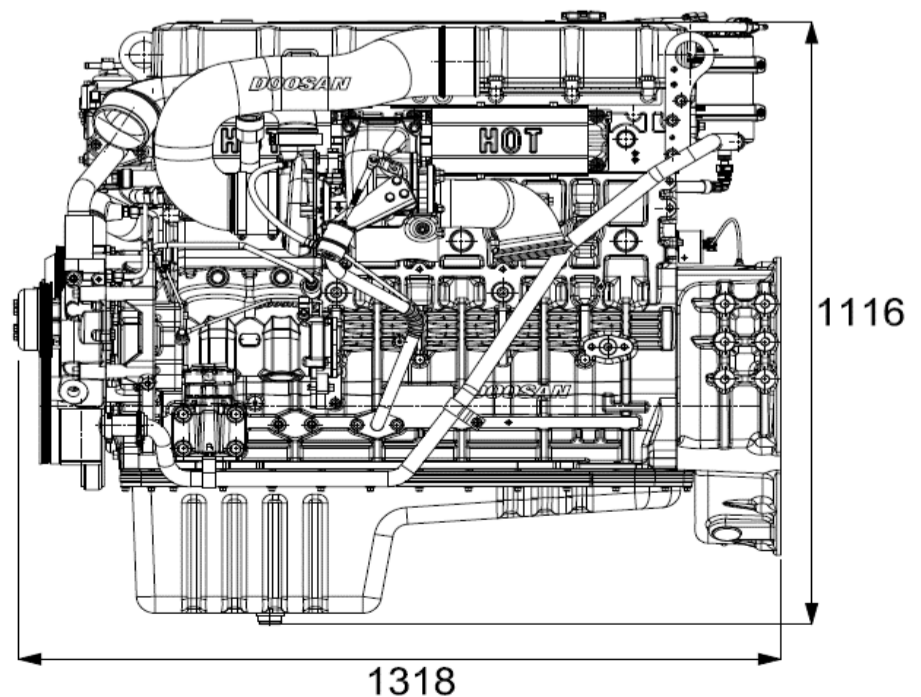
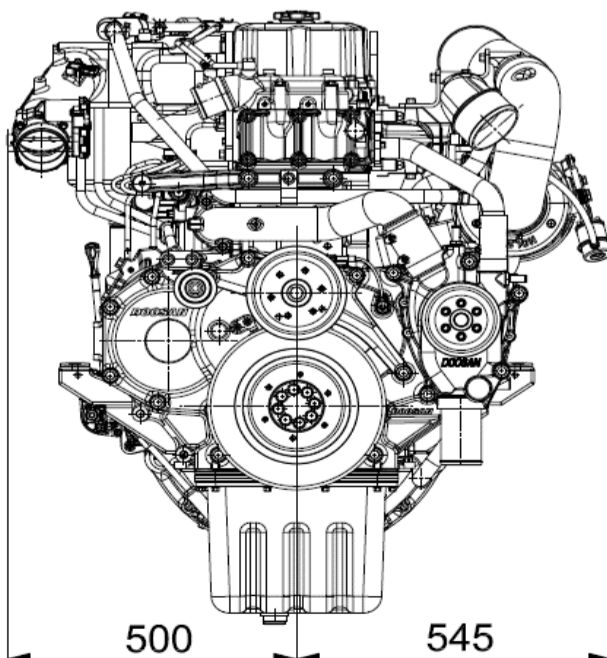

© Performance Curve

○ 338kW (460PS) / 225kg.m

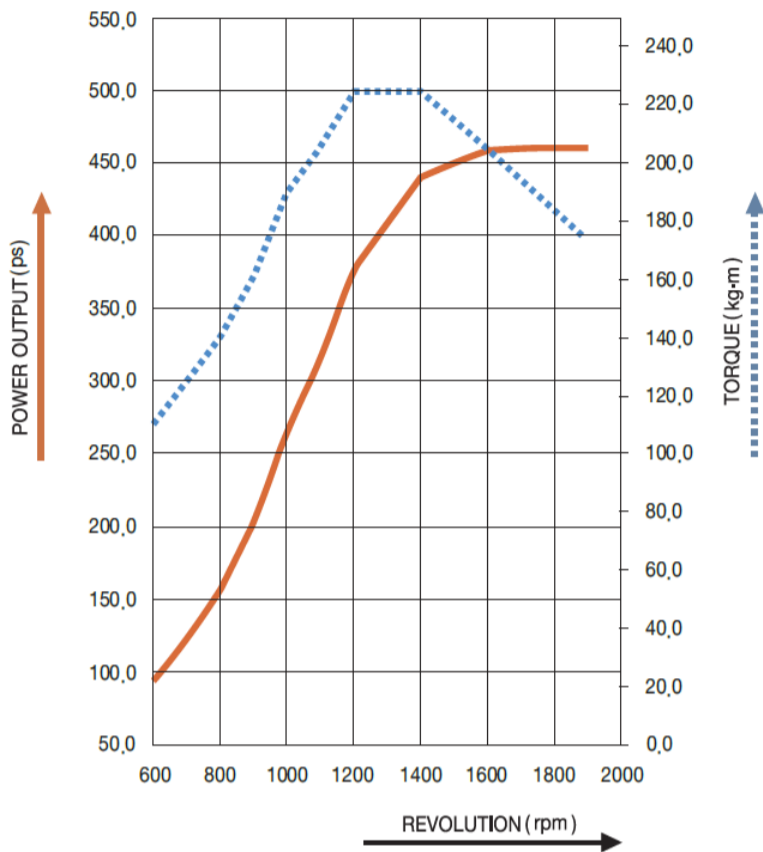

○ 324kW (440PS) / 203kg.m

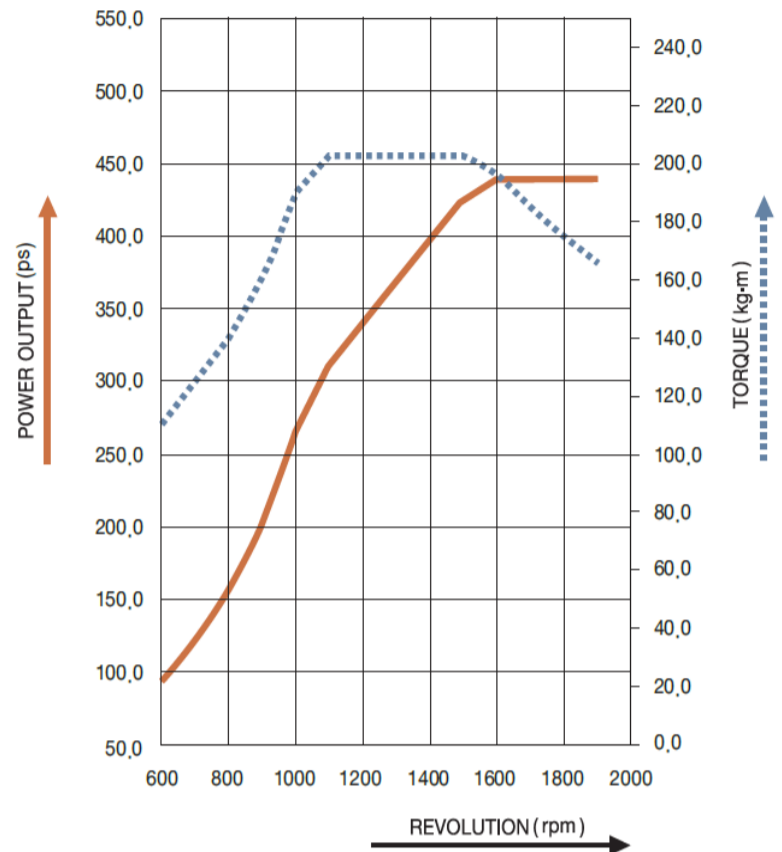

© Aftertreatment System

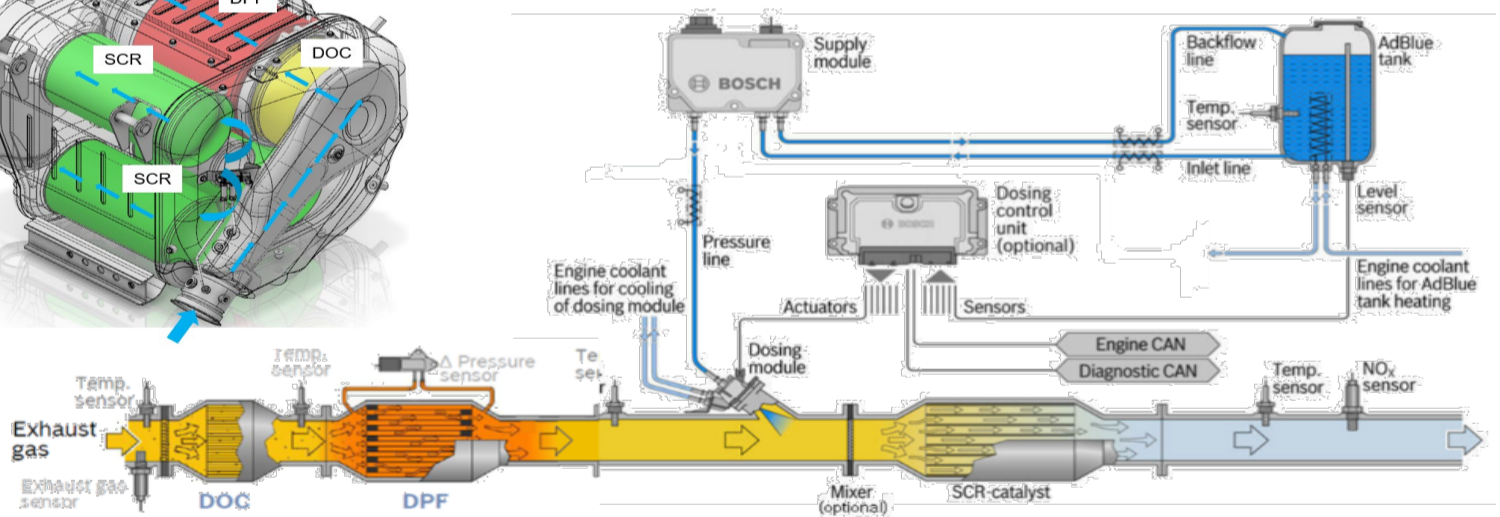
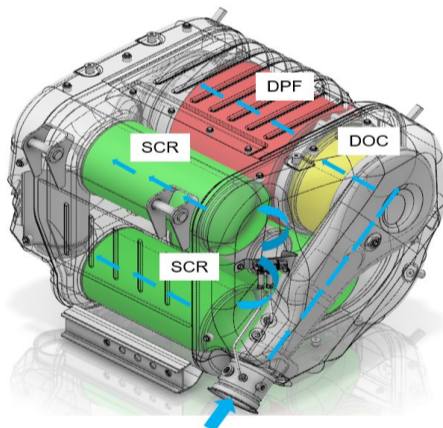

Head office

HD Hyundai Group's Global R&D Center 477,
Bundangsuseo-ro, Seongnam-si Gyeonggi-do,
Korea (13553)

Sales office (Engine)

11F, HD Hyundai Group's Global R&D Center